

JELD-WEN®

CONTOURS STEEL DOOR, WOOD EDGE

6-0 X 6-8 (XX) & 5-4 X 8-0 (O/OXO)

INSWING/OUTSWING

24 GA. STEEL IMPACT DOOR SYSTEM

GENERAL NOTES

1. THE PRODUCT SHOWN HEREIN IS DESIGNED TO COMPLY WITH THE CURRENT IRC AND FLORIDA BUILDING CODE (FBC) BASED ON THE SIGNED AND SEALED DATE. PRODUCT HAS BEEN TESTED TO ASTM E330-02, E331-00, E283-04, E1886-05, E1996-05b & AAMA 1304-02. SINGLE AND DOUBLE DOOR SYSTEMS PASS WINDZONE (WD) 4 RATING. DOOR SYSTEMS HAVING SIDELITE/TRANSOM COMBINATIONS RATE AT WINDZONE (WD) 3.
NOTE: GLAZING IN SIDELITES AND TRANSOM ARE NOT IMPACT RATED.
2. 2X AND 1X WOOD BUCKS BY OTHERS, MUST BE ANCHORED PROPERLY TO TRANSFER LOADS TO THE STRUCTURE.
3. PRODUCT ANCHORS SHALL BE AS LISTED AND SPACED AS SHOWN ON DETAILS. ANCHOR EMBEDMENT TO BASE MATERIAL SHALL BE BEYOND WALL DRESSING OR STUCCO.
4. FOR DESIGN PRESSURE RATING SEE TABLE I, SHEET 1.
5. SCALE BASED ON 11x17 SHEET SIZE.
6. ALL 1X & 2X TO BE 0.55 SPECIFIC GRAVITY OR GREATER.
7. FLORIDA APPROVED IMPACT RESISTANT SHUTTERS ARE REQUIRED FOR SIDELITES AND TRANSOMS.
8. PRODUCT HAS NOT BEEN RATED FOR WATER INFILTRATION. IF AUTHORITY HAVING JURISDICTION REQUIRES THAT PRODUCT MEETS THIS REQUIREMENT, PRODUCT SHALL BE USED WHEN INSTALLED AT LOCATION PROTECTED BY OVERHANG SUCH THAT OVERHANG (OH) RATIO = OH LENGTH/OH HEIGHT IS 1.0.

DOOR LEAF CONSTRUCTION:

FACE SHEETS: THE FACE SHEETS ARE GLUED TO THE CORE AND SUBSTRATE WITH LMC ADHESIVE.

CORE DESIGN: BY JELD-WEN.

PANEL CONSTRUCTION: EACH DOOR PANEL IS CONSTRUCTED FROM TWO SHEETS OF 24-GAUGE (.021" MIN) GALVANIZED STEEL. THE AVERAGE MIN. YIELD STRENGTH OF 24 GA SHEET METAL SKIN IS 40,300 psi. THE FACE SHEETS ARE BENT 90° OVER THE 1.688" X 1.0" LVL (LAMINATED VENEER LUMBER) STILES AND TOP RAIL. THE 1.688" X 1.203" BOTTOM RAIL CONSISTS OF ROLLED-FORMED GALVANIZED 25-GAUGE (.018" MIN) STEEL. THE LOCK BLOCK IS 1.688" X 3 1/8" X 12" FINGER JOINTED PINE.

SIDELITE CONSTRUCTION: EACH SIDELITE IS CONSTRUCTED THE SAME AS A DOOR PANEL, INCLUDING CORE DESIGN, BUT EXCLUDING THE WOOD LOCK BLOCK. INSULATED GLAZING CONSISTS OF TWO 0.125" TEMPERED GLASS PANES SEPARATED BY A 0.75" AIR SPACE.

FRAME CONSTRUCTION: THE FRAME JAMBS AND HEAD ARE CONSTRUCTED OF WOOD. THE OUTSWING SILL IS COMPRISED OF COMPOSITE MATERIAL WITH ALUMINUM CLADDING. THE INSWING SILL IS COMPRISED OF A COMPOSITE MATERIAL WITH AN ALUMINUM CLADDING AND A PLASTIC ADJUSTABLE HEIGHT THRESHOLD. ALL BOTTOM FRAME CORNERS ARE COPED, BUTTED, SEALED USING SILICONE AND FASTENED USING THREE 16 GA. 7/16" X 2" LONG STAPLES AND ONE #8X2 FH WOOD SCREW PER CORNER. INSWING SYSTEMS HAVE A #8X2 FH WOOD SCREW IN EACH SILL/JAMB CORNER ANGLED FROM SILL INTO THICK PORTION OF JAMB. TOP FRAME CORNERS ARE COPED, BUTTED, SEALED USING SILICONE AND FASTENED USING FOUR 16 GA. 7/16" X 2" LONG STAPLES AND ONE #8X2 FH WOOD SCREW PER CORNER. INSWING UNITS WITH A GLOBAL ASTRAGAL ATTACHED TO THE INACTIVE PANEL, HAVE A 7/16" HOLE DRILLED AT THE CENTER OF THE SILL THRESHOLD AND FILLED WITH DOW 1199 SILICONE. A PLASTIC RECEIVER PLUG IS INSERTED TO RECEIVE THE BOTTOM ASTRAGAL BOLT. OUTSWING UNITS WITH AN INACTIVE PANEL, TAKE A 1/2" HOLE AT THE CENTER OF THE SILL AND A METAL STRIKE PLATE IS FASTENED USING TWO #8 X 2-1/2" SCREWS TO RECEIVE THE BOTTOM ASTRAGAL BOLT. INSWING AND OUTSWING UNITS TAKE A 1/2" HOLE AT THE CENTER OF THE HEAD AND A METAL STRIKE PLATE IS FASTENED USING TWO #8 X 2 1/2" SCREWS TO RECEIVE THE TOP ASTRAGAL BOLT. ALL FRAME JOINERY ARE SEALED AT THE EXTERIOR USING DOW 1199 SILICONE.

TRANSOM FRAME CONSTRUCTION: FRAME HEADS, SILLS AND JAMBS ARE MADE OF LAMINATED VENEER LUMBER (LVL). THE FRAME CORNERS ARE JOINED USING RABBET

JOINTS, SILICONE SEALANT AND FOUR 16GA X 7/16" X 2" LONG CROWN STAPLES THROUGH THE JAMB. THE MULLION TO DOOR/SIDELITE IS CREATED BY SANDWICHING SILICONE SEALANT BETWEEN THE JAMBS OF THE TWO FRAMES. 1" X 1/2" CORRUGATED NAILS ARE USED ON THE EXTERIOR SIDE TO FASTEN THE JAMBS TOGETHER AND #8 X 2" SCREWS ARE INSTALLED THROUGH JAMBS ON THE INTERIOR SIDE. A WOOD MULLION COVER IS THEN INSTALLED OVER THE ENTIRE LENGTH OF THE EXTERIOR JOINT, SEALED WITH SILICONE SEALANT AND HELD IN PLACE WITH 16GA X 7/16" X 2" STAPLES.

TRANSOM GLAZING: THE GLAZING CONSISTS OF 2 PIECES OF 1/8" ANNEALED GLASS AND ARE HELD IN PLACE BY THE SASH AND THE GLAZING CLIP. AN ALUMINUM SPACER BETWEEN THE GLASS PROVIDES A 7/16" AIR GAP.

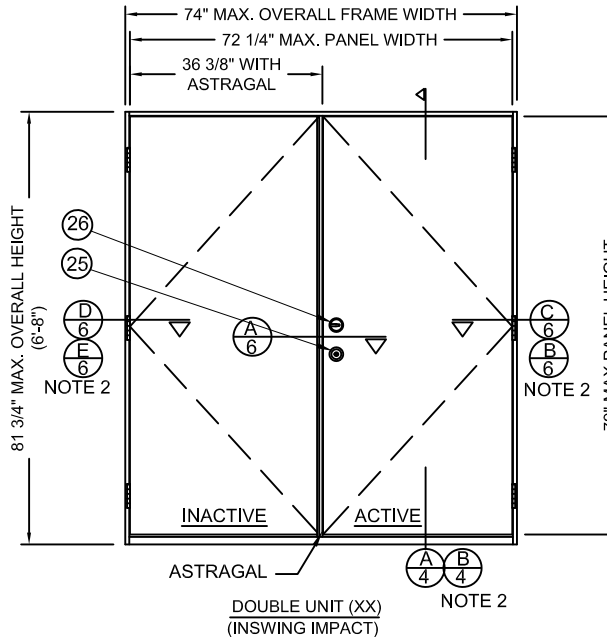

TABLE OF CONTENTS	
SHT #	DESCRIPTION
1	INSWING ELEVATIONS & GENERAL NOTES
2	INSWING ELEVATIONS
3	INSWING ELEVATIONS & BILL OF MATERIAL
4	INSWING VERTICAL CROSS SECTIONS
5	INSWING VERTICAL CROSS SECTIONS
6	INSWING HORIZONTAL CROSS SECTIONS
7	INSWING HORIZONTAL CROSS SECTIONS
8	OUTSWING ELEVATIONS
9	OUTSWING VERTICAL CROSS SECTIONS
10	OUTSWING VERTICAL CROSS SECTIONS
11	OUTSWING HORIZONTAL CROSS SECTIONS
12	OUTSWING HORIZONTAL CROSS SECTIONS
13	ANCHORING LOCATIONS
14	ANCHORING LOCATIONS
15	ANCHORING LOCATIONS & DETAILS
16	UNIT COMPONENTS

TABLE 1

		DESIGN PRESSURE RATING	
		DESIGN PRESSURE RATING:	
		SINGLE DOOR WITH & WITHOUT SIDELITE(S) AND/OR TRANSOM	DOUBLE DOOR W/O SIDLITE OR TRANSOM
INSWING	POSITIVE	+55	+55
	NEGATIVE	-55	-55
OUTSWING	POSITIVE	+55	+55
	NEGATIVE	-55	-55

- NOTES:
 1. ALL VIEWS FROM INTERIOR.
 2. MASONRY AND CONCRETE CONSTRUCTION.

HERMES F. NORERO, P.E.
 Texas No. 11847
 308 East Dania Beach Blvd, Suite 398
 Dania Beach, FL 33004

JELD-WEN, INC.
 3737 LAKEPORT BLVD.
 KLAMATH FALLS, OR, 97601
 PH. 541-882-3451

PRODUCT:
 CONTOURS STEEL DOOR, WOOD EDGE
 6-0x6-8 (XX) & 5-4x6-8 (O/OXO)
 INSWING/OUTSWING 24GA. STEEL
 PART OR ASSEMBLY:
 INSWING ELEVATIONS &
 GENERAL NOTES

NO	DATE	DESCRIPTION	BY
D	01.14.20	ADDED ADA THRESHOLD	TB
C	08.23.17	CHGD CORE DEFIN.	JH
B	10.27.14	5TH ED CODE CHANGE	SM
A	12.01.11	2010 CODE CHANGE	JLA

DATE: 12/31/09
 SCALE: 1/2" = 1'
 DWG. BY: G. LUBBECKE
 CHK. BY: S. FREY
 DRAWING NO.: JW162009
 SHEET 1 OF 16

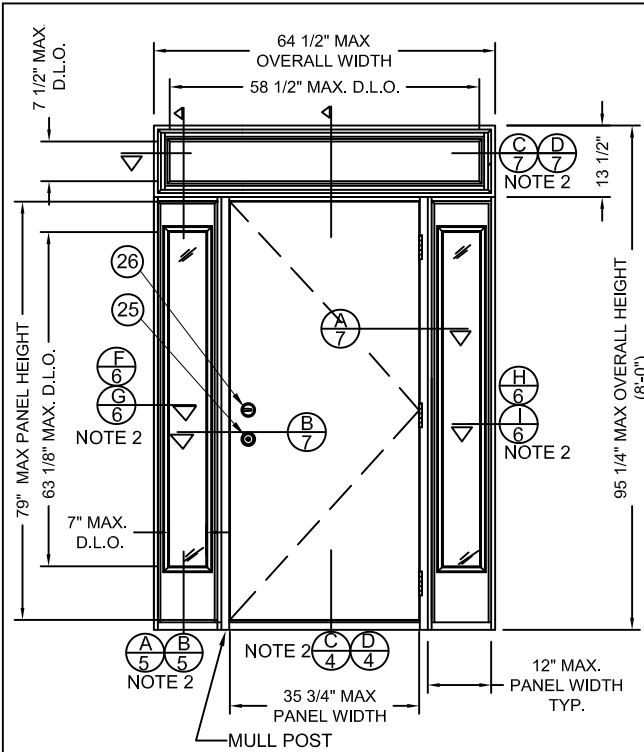

TRI UNIT (O/OX)
(INSWING IMPACT DOOR WITH
NON-IMPACT SIDELITES & TRANSOM)

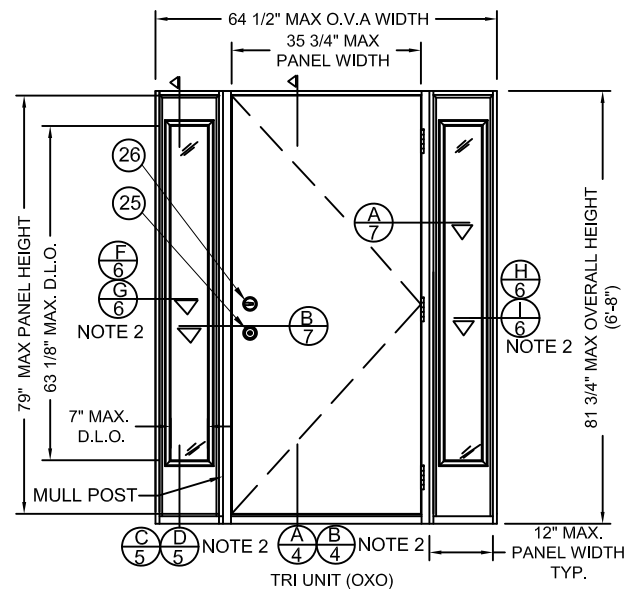

TRI UNIT (OX)
(INSWING IMPACT DOOR WITH
NON-IMPACT SIDELITES)

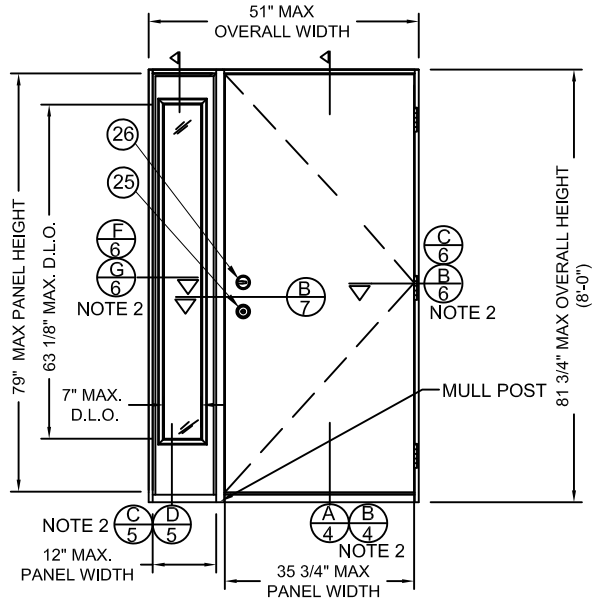

DUAL UNIT (OX)
(INSWING IMPACT DOOR WITH
NON-IMPACT SIDELITE)

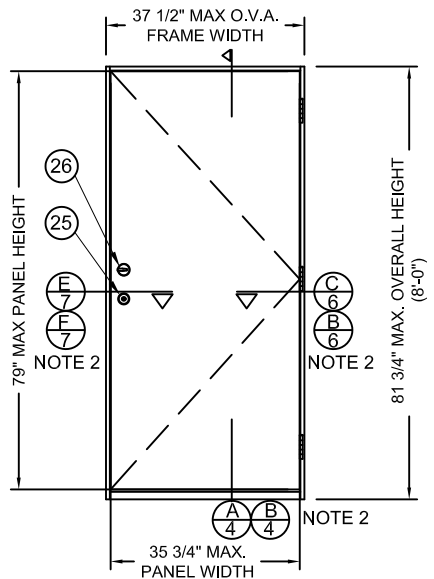

SINGLE UNIT (X)
(INSWING IMPACT)

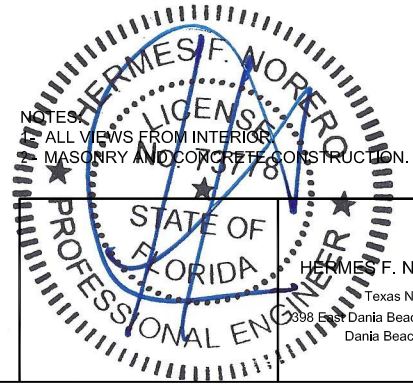

HERMES F. NORERO, P.E.
Texas No. 11847
398 East Dania Beach BLVD, Suite 398
Dania Beach, FL 33004

JELD-WEN, INC.
3737 LAKEPORT BLVD.
KLAMATH FALLS, OR, 97601
PH. 541-882-3451

PRODUCT:
CONTOURS STEEL DOOR, WOOD EDGE
6-0x6-8 (XX) & 5-4x6-8 (O/OXO)
INSWING/OUTSWING 24GA. STEEL
PART OR ASSEMBLY:
INSWING ELEVATIONS

NO	DATE	DESCRIPTION	BY
D	01.14.20	ADDED ADA THRESHLD	TB
C	08.23.17	CHGD CORE DEFIN	JH
B	10.27.14	5TH ED CODE CHANGE	SM
A	12.01.11	2010 CODE CHANGE	JLA

DATE: 12/31/09
SCALE: 1/2" = 1'
DWG. BY: LUBBECKE
CHK. BY: S. FREY
DRAWING NO.: JW162009
SHEET 2 OF 16

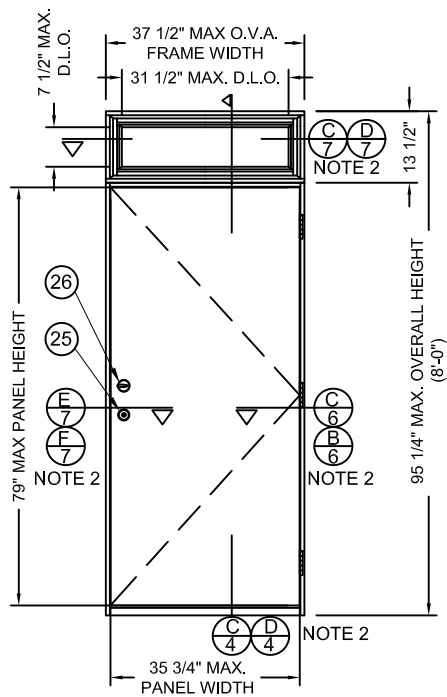

SINGLE UNIT (O/X)
(INSWING IMPACT DOOR WITH
NON-IMPACT TRANSOM)

Item	DESCRIPTION	Material
1	HINGE JAMB (1 1/4" X 4-9/16" FINGERJOINTED PINE)	PINE
2	HEAD JAMB (1 1/4" X 4-9/16" FINGERJOINTED PINE)	PINE
3	LATCH JAMB (1-1/4" X 4-9/16" FINGERJOINTED PINE)	PINE
4	SIDELITE JAMB (1-1/4" X 4-9/16" FINGERJOINTED PINE)	PINE
5	#10 PHILLIPS FLATHEAD WOOD SCREW WITH 1 1/2" MIN. EMBEDMENT	STEEL
6	4" X 4" BUTT HINGE 12GA. (.089" MIN)	STEEL
7	#9 X 3/4" PHILLIPS FLATHEAD WOOD SCREW	STEEL
8	#10 X 1 1/2" PHILLIPS FLATHEAD WOOD SCREW	STEEL
9	3/16" ITW BUILDIX TAPCON WITH 1 1/4" MIN. EMBEDMENT	STEEL
10	COMPRESSION WEATHERSTRIP	FOAM
11	INSWING THRESHOLD 6063-T5/COMP.	ALUMINUM
12	#8 X 2 1/2" PHILLIPS FLAT HEAD WOOD SCREW	STEEL
13	EXTRUDED ASTRAGAL (GLOBAL) 6063-T6 AL	ALUMINUM
14	NOT USED	
15	SIDELITE SEAT	VINYL
16	TOP RAIL LAMINATED VENEER LUMBER (LVL)	LVL
17	BOTTOM RAIL 25GA. (0.018") GALVANIZED STEEL	STEEL
18	HINGE SIDE STILE LAMINATED VENEER LUMBER (LVL)	LVL
19	LATCH SIDE STILE LAMINATED VENEER LUMBER (LVL)	LVL
20	LOCK BLOCK 1-11/16" X 3-1/8" X 12 FINGERJOINTED PINE TREATED	PINE
21	ODL LIP-LITE FRAME	PLASTIC
22	1" O.V.A. INSULATED TEMPERED GLASS	GLASS
23	16 Ga. 7/16" CROWN X 2" LONG STAPLES	STEEL
24	CORRUGATED NAIL 1/2" X 1-1/16" 25 GA.	STEEL
25	KWIKSET LOCK SERIES 400	STEEL
26	KWIKSET DEADBOLT SERIES 660	STEEL
27	#8 X 2" PHILLIPS FLATHEAD WOOD SCREW	STEEL
28	2X WOOD BUCK GRADE 2 SOUTHERN YELLOW PINE	WOOD
29	NON-COMPRESSION SHIM	WOOD
30	DOOR CORE BY JELD-WEN	FOAM
31	STEEL DOOR PANEL SKIN MATERIAL (24 GA GALVANIZED) A-525 COMMERCIAL QUALITY 0.021" MIN. THICK.)	FIBERGLASS
32	INSWING VINYL DOOR BOTTOM SWEEP	VINYL
33	CORNER PADS 2", LOCATED AT THE BOTTOM OF EACH JAMB LEG SETTING ON TOP OF THE SILL, BEHIND THE WEATHERSTRIP	FOAM
34	OUTSWING THRESHOLD 6063-T5/COMPOSITE	ALUMINUM
35	MULL POST, EDGE GLUED FINGERJOINTED PINE	PINE
36	3/8" ROUNDED SCOTIA	PLASTIC
37	SILICONE BEAD DOW 1199	SILICONE
38	JAMB, 1-1/4" X 4-1/2" FINGERJOINTED PINE	LVL
39	OUTSWING THRESHOLD 6063-T5	ALUMINUM
40	ASTRAGAL BOLT 0.313 DIA.	STEEL
41	OPTIONAL 1X WOOD BUCK GRADE 2 SOUTHERN YELLOW PINE	WOOD
42	11/16 O.V.A. INSULATED 1/8" ANNEALED GLASS	GLASS
43	1" STEEL BRAD	STEEL
44	ALUMINUM GLAZING SPACER	AL/SEALANT
45	GLAZING CLIP	CELLULAR PVC
46	SASH	CELLULAR PVC
47	STRIKE PLATE (GLOBAL)	STEEL
48	DEAD BOLT BACK PLATE (SINGLE DOOR SYSTEMS ONLY)	STEEL
49	BOTTOM ASTRAGAL INSERT PLUG (GLOBAL)	PLASTIC
50	ADA THRESHOLD	ALUMINUM

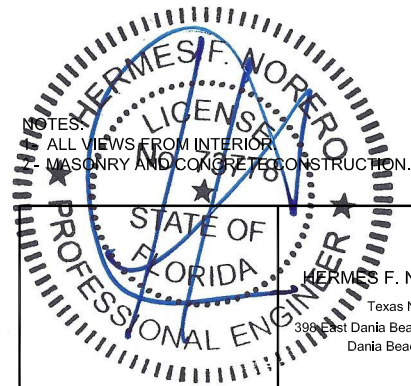

JELD-WEN, INC.
3737 LAKEPORT BLVD.
KLAMATH FALLS, OR, 97601
PH. 541-882-3451

PRODUCT:
CONTOURS STEEL DOOR, WOOD EDGE
6-0X6-8 (XX) & 5-4X6-8 (O/OXO)
INSWING/OUTSWING 24GA. STEEL
PART OR ASSEMBLY:
INSWING ELEVATIONS &
BILL OF MATERIALS

NO.	DATE	DESCRIPTION	BY
D	01.14.20	ADDED ADA THRESHLD	TB
C	08.23.17	CHGD CORE DEFIN	JH
B	10.27.14	5TH ED CODE CHANGE	SM
A	12.01.11	2010 CODE CHANGE	JLA

DATE: 12/31/09
SCALE: 1/2" = 1'
DWG. BY: G. LUBBECKE
CHK. BY: S. FREY
DRAWING NO.: JW162009
SHEET 3 OF 16

HERMES F. NORERO, P.E.
Texas No. 11847
390 East Dania Beach BLVD, Suite 398
Dania Beach, FL 33004

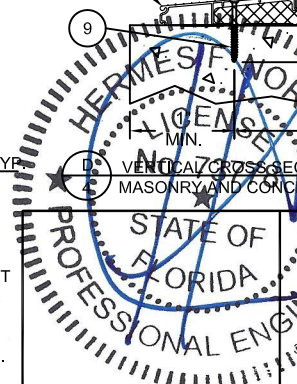
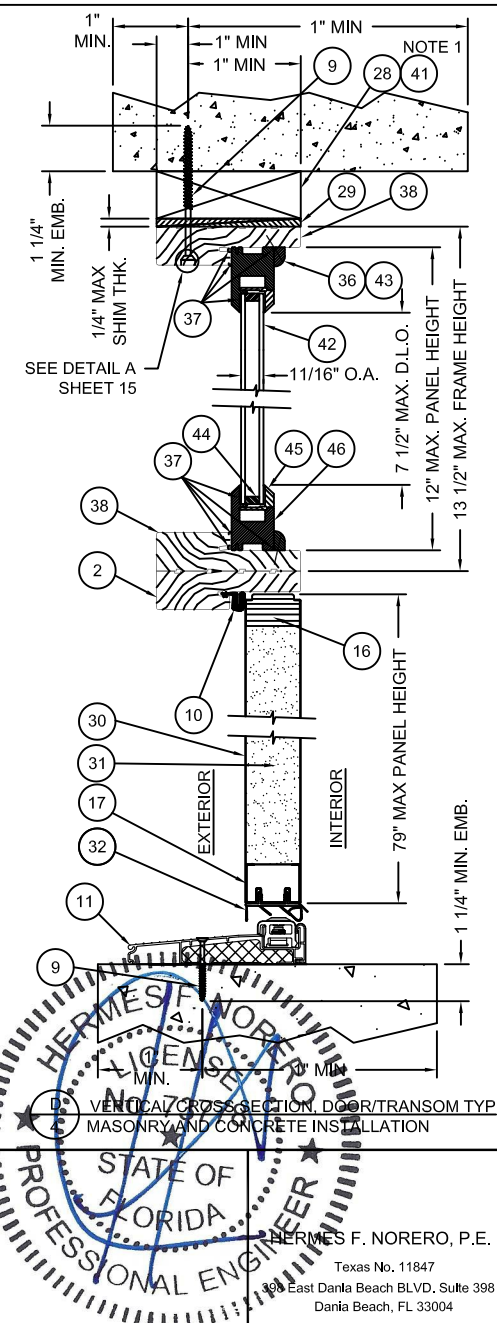
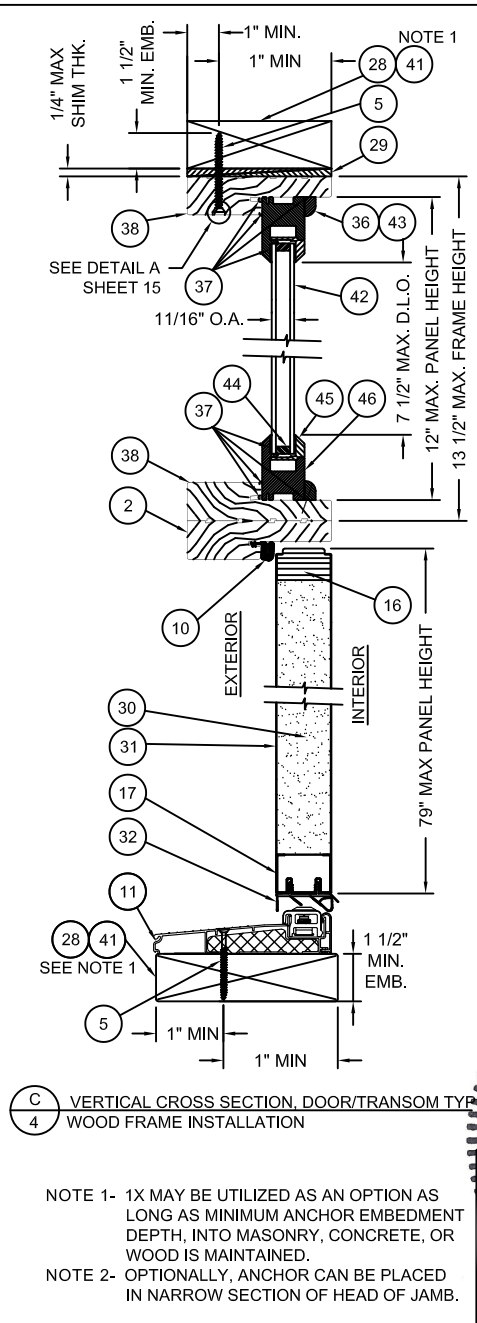
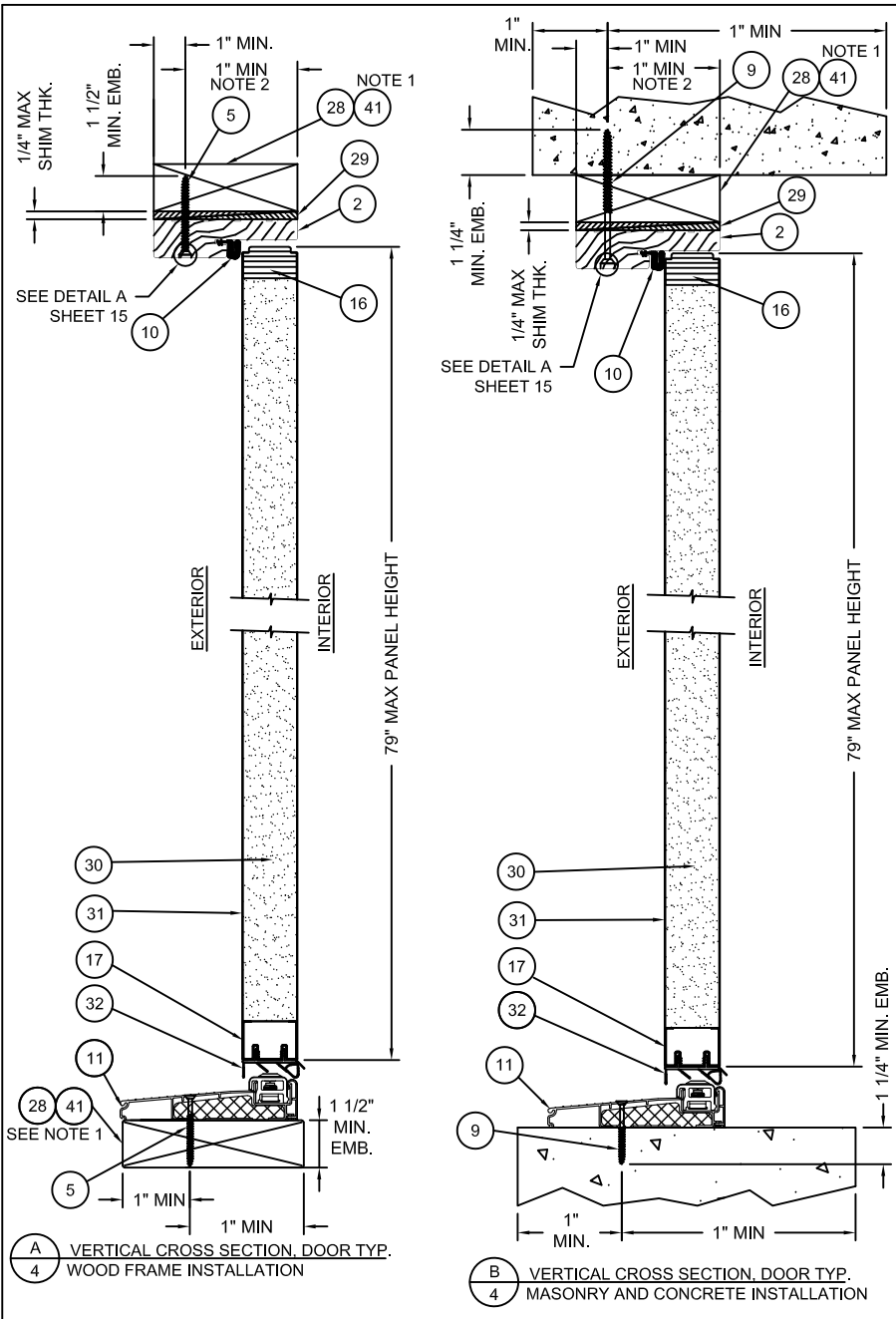

JELD-WEN, INC.
 3737 LAKEPORT BLVD.
 KLAMATH FALLS, OR, 97601
 PH. 541-882-3451

PRODUCT:	CONTOURS STEEL DOOR, WOOD EDGE 6-0x6-8 (XX) & 5-4x6-8 (O/OXO) INSWING/OUTSWING 24GA. STEEL		
NO.	DATE	DESCRIPTION	BY
D	01.14.20	ADDED ADA THRESHLD	TB
C	08.23.17	CHGD CORE DEFIN	JH
B	10.27.14	5TH ED CODE CHANGE	SM
A	12.01.11	2010 CODE CHANGE	JLA

DATE: 12/31/09
 SCALE: 3" = 1"
 DWG. BY: LUBBECKE
 CHK. BY: S. FREY
 DRAWING NO.: JW162009
 SHEET 4 OF 16

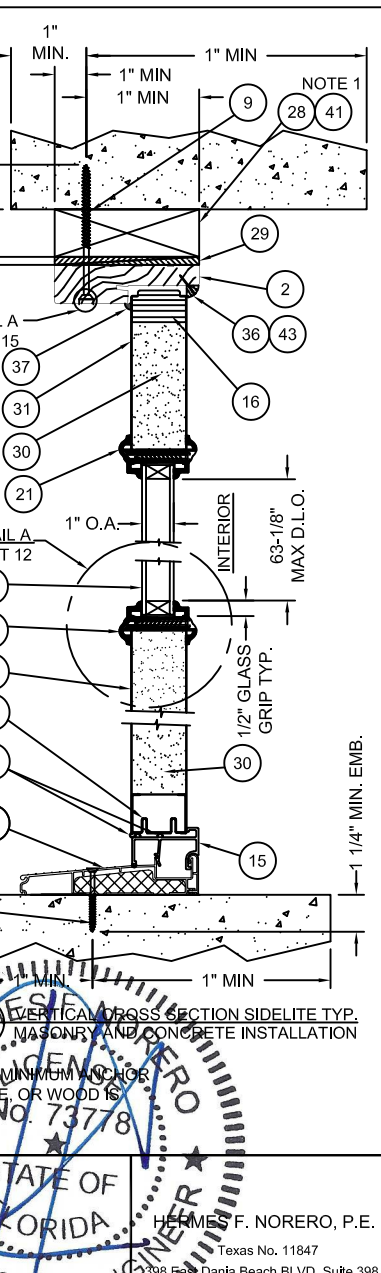
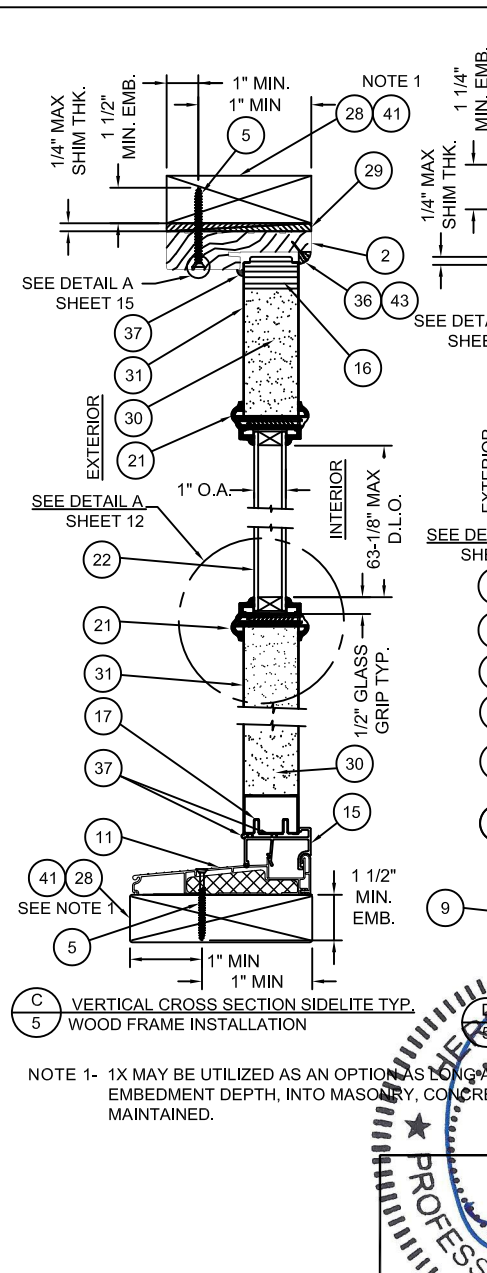
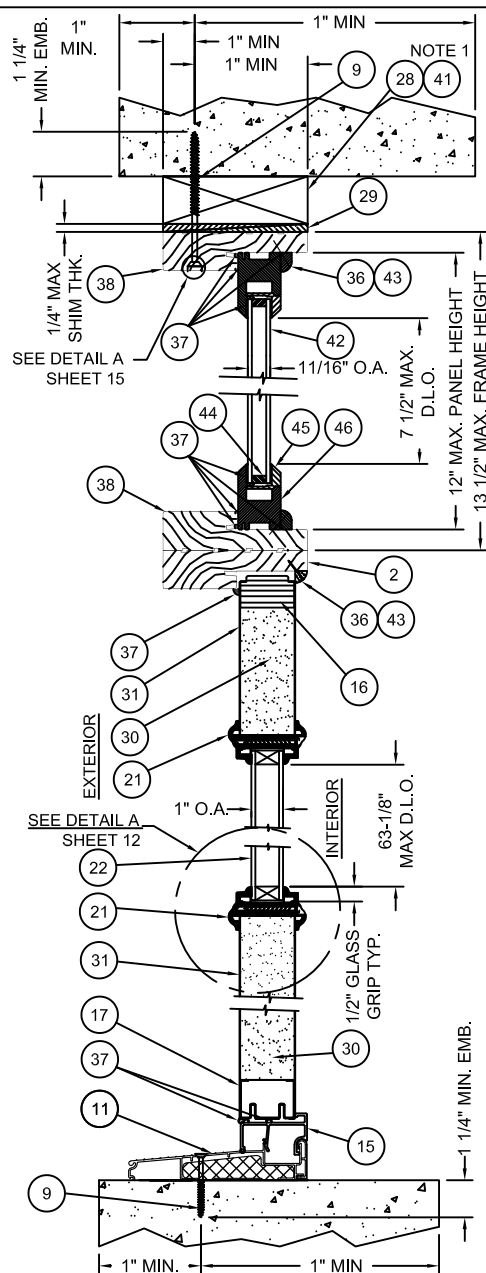
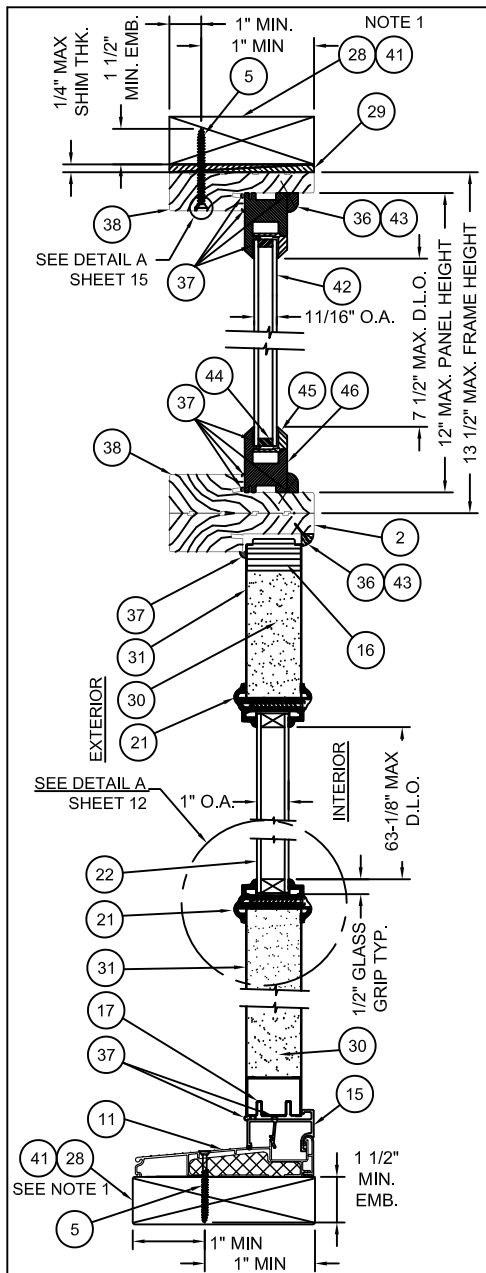

(A) 5 VERTICAL CROSS SECTION SIDELITE /TRANSOM TYP. WOOD FRAME INSTALLATION

(B) 5 VERTICAL CROSS SECTION SIDELITE /TRANSOM TYP. MASONRY AND CONCRETE INSTALLATION

(C) 5 VERTICAL CROSS SECTION SIDELITE TYP. WOOD FRAME INSTALLATION

(D) 5 VERTICAL CROSS SECTION SIDELITE TYP. MASONRY AND CONCRETE INSTALLATION

NOTE 1- 1X MAY BE UTILIZED AS AN OPTION AS LONG AS MINIMUM ANCHOR EMBEDMENT DEPTH, INTO MASONRY, CONCRETE, OR WOOD IS MAINTAINED.

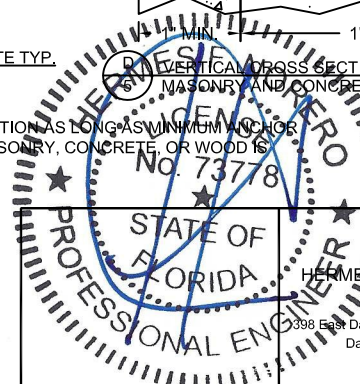

HERMES F. NORERO, P.E.
Texas No. 11847
398 East Dania Beach BLVD, Suite 398
Dania Beach, FL 33004

JELD-WEN, INC.
3737 LAKEPORT BLVD.
KLAMATH FALLS, OR, 97601
PH. 541-882-3451

PRODUCT:
CONTOURS STEEL DOOR, WOOD EDGE
6-0x6-8 (XX) & 5-4x6-8 (O/OXO)
INSWING/OUTSWING 24GA. STEEL
PART OR ASSEMBLY:
INSWING VERTICAL CROSS SECTIONS

NO.	DATE	DESCRIPTION	BY

DATE: 12/31/09
SCALE: 3" = 1"
DWG. BY: G. LUBBECKE
CHK. BY: S. FREY
DRAWING NO.: JW162009
SHEET 5 OF 16

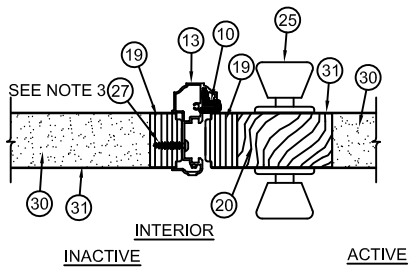

A HORIZONTAL CROSS SECTION
VIEW AT ASTRAGAL

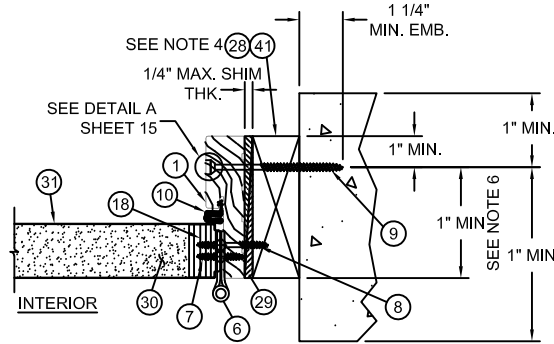

B HORIZONTAL CROSS SECTION
VIEW AT DOOR HINGE/SIDE JAMB
(MASONRY AND CONCRETE INSTALL)

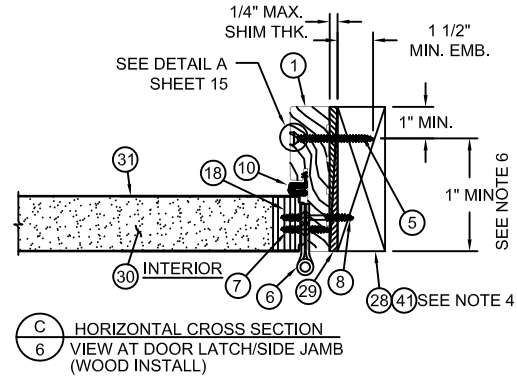

C HORIZONTAL CROSS SECTION
VIEW AT DOOR LATCH/SIDE JAMB
(WOOD INSTALL)

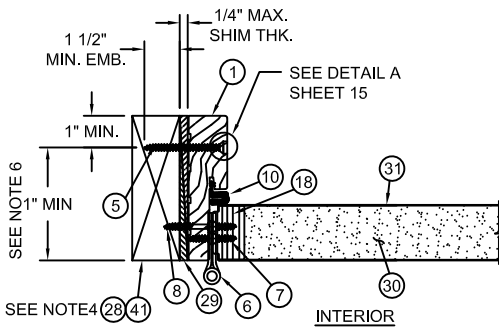

D HORIZONTAL CROSS SECTION
VIEW AT DOOR HINGE/SIDE JAMB
(WOOD INSTALL)

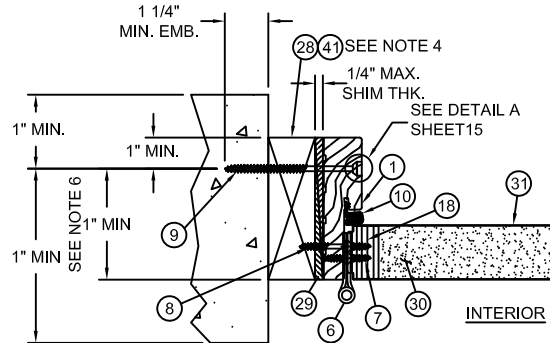

E HORIZONTAL CROSS SECTION
VIEW AT DOOR HINGE/SIDE JAMB
(MASONRY AND CONCRETE INSTALL)

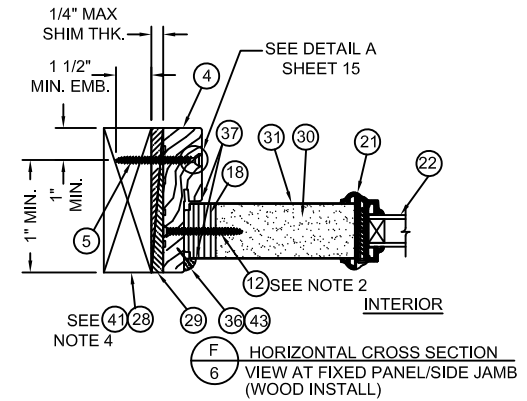

F HORIZONTAL CROSS SECTION
VIEW AT FIXED PANEL/SIDE JAMB
(WOOD INSTALL)

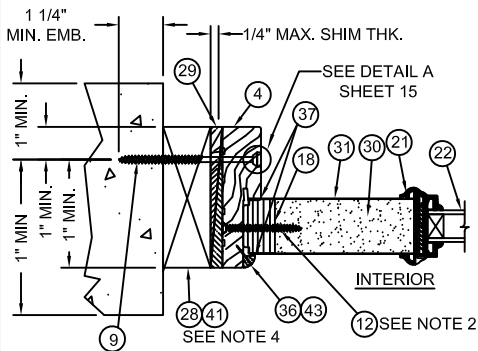

G HORIZONTAL CROSS SECTION
VIEW AT FIXED PANEL/SIDE JAMB
(MASONRY AND CONCRETE INSTALL)

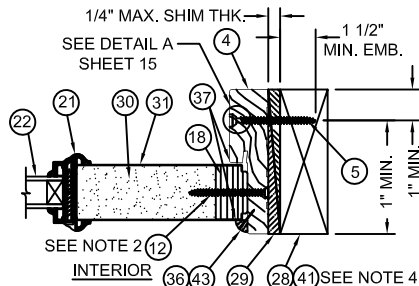

H HORIZONTAL CROSS SECTION
VIEW AT FIXED PANEL/SIDE JAMB
(WOOD INSTALL)

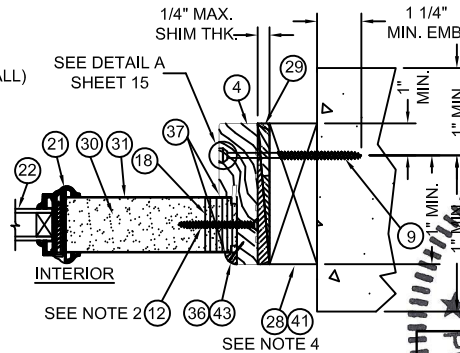

I HORIZONTAL CROSS SECTION
VIEW AT FIXED PANEL/SIDE JAMB
(MASONRY AND CONCRETE INSTALL)

NOTES

- FOR ANCHOR SPACING, SEE SHEETS 13, 14 & 15.
- SPACING FOR ITEM #12 FROM TOP DOWN: 6", 28-5/8", 50-7/8", 73-1/4".
- ASTRAGAL SCREW SPACING FOR ITEM #27 FROM TOP DOWN: 1/2", 3-1/2", 20", 24-3/4", 54-1/4", 59" 75-1/4" & 79-1/4".
- BUCK MAY BE UTILIZED AS AN OPTION AS LONG AS MIN. ANCHOR EMBEDMENT DEPTH INTO MASONRY, CONCRETE, OR WOOD IS MAINTAINED.
- FOR ITEM #9 ANCHOR SPACING SAME AS WOOD ANCHOR (ITEM #5) SPACING.
- OPTIONALLY ANCHOR CAN BE PLACED IN NARROW SECTION OF HEAD OF JAMB.

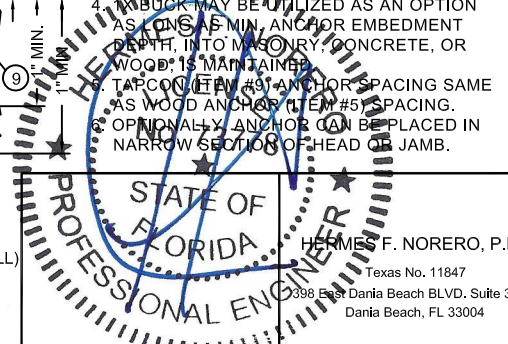

JELD-WEN, INC.
3737 LAKEPORT BLVD.
KLAMATH FALLS, OR, 97601
PH. 541-882-3451

PRODUCT: CONTOURS STEEL DOOR, WOOD EDGE
6-0x6-8 (XX) & 5-4x6-8 (O/OXO)
INSWING/OUTSWING 24GA. STEEL
PART OR ASSEMBLY:
INSWING HORIZONTAL CROSS SECTIONS

NO.	DATE	DESCRIPTION	BY
D	01.14.20	ADDED ADA THRESHLD	TB
C	08.23.17	CHGD CORE DEFN.	JH
B	10.27.14	5TH ED CODE CHANGE	SM
A	12.07.11	2010 CODE CHANGE	JLA

DATE: 12/31/09
SCALE: 3" = 1"
DWG. BY: LUBBECKE
CHK. BY: S. FREY
DRAWING NO.: JW162009
SHEET 6 OF 16

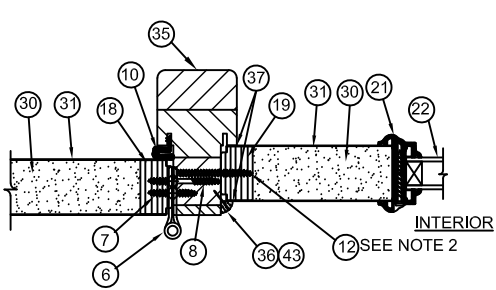

A HORIZONTAL CROSS SECTION
7 VIEW AT HINGED PANEL/SIDE LITE AT MULLION

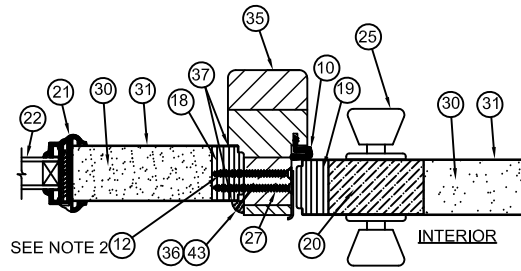

B HORIZONTAL CROSS SECTION
7 VIEW AT FIXED PANEL/DOOR LATCH AT MULLION

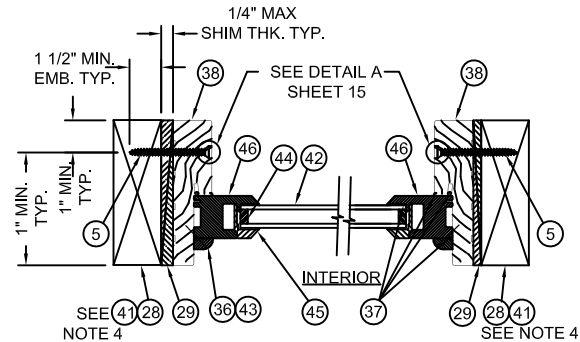

C HORIZONTAL CROSS SECTION
7 VIEW AT FIXED TRANSOM
(WOOD INSTALL)

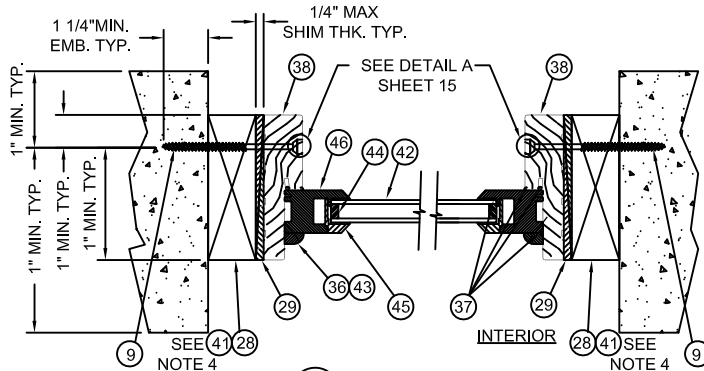

D HORIZONTAL CROSS SECTION
7 VIEW AT FIXED TRANSOM
(MASONRY AND CONCRETE INSTALL)

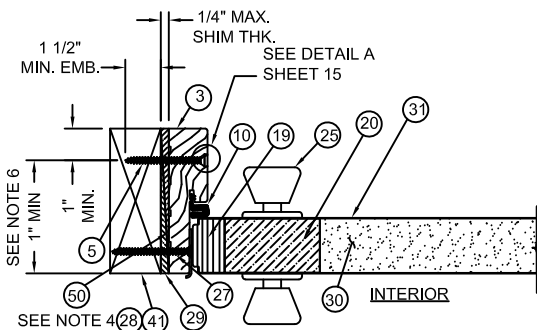

E HORIZONTAL CROSS SECTION
7 VIEW AT DOOR LATCH/SIDE JAMB
(WOOD INSTALL)

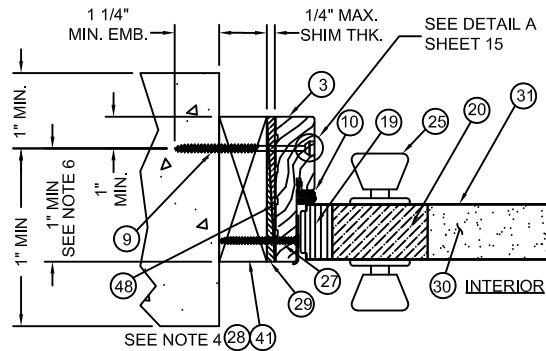

F HORIZONTAL CROSS SECTION
7 VIEW AT DOOR LATCH/SIDE JAMB
(MASONRY AND CONCRETE INSTALL)

NOTES

1. FOR ANCHOR SPACING, SEE SHEETS 13, 14 & 15.
2. SPACING FOR ITEM #12 FROM TOP DOWN: 6", 28^{3/8"}, 50^{1/4"}, 73^{1/4"}.
3. ASTRAGAL SCREW SPACING FOR ITEM #27 FROM TOP DOWN: 1/2", 3-3/4", 20", 24-3/4", 54-1/4", 59" 75-1/2" & 78-1/2".
4. 1X BUCK MAY BE UTILIZED AS AN OPTION AS LONG AS MIN. ANCHOR EMBEDMENT DEPTH, INTO MASONRY, CONCRETE, OR WOOD, IS MAINTAINED.
5. TAPCON (ITEM #9) ANCHOR SPACING SAME AS WOOD ANCHOR (ITEM #5) SPACING.
6. OPTIONALLY, ANCHOR CAN BE PLACED IN NARROW SECTION OF HEAD OR JAMB.

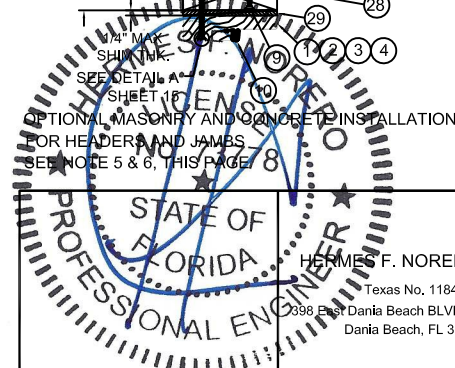
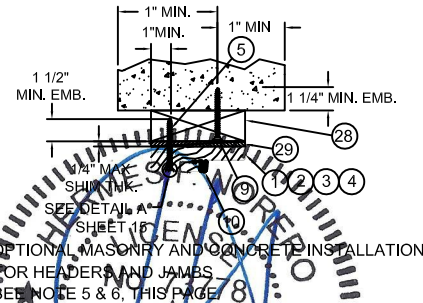

JELD-WEN, INC.
3737 LAKEPORT BLVD.
KLAMATH FALLS, OR, 97601
PH. 541-882-3451

PRODUCT:	CONTOURS STEEL DOOR, WOOD EDGE
	6-0x6-8 (XX) & 5-4x6-8 (O/OXO)
	INSWING/OUTSWING 24GA. STEEL
	PART OR ASSEMBLY:
	INSWING HORIZONTAL CROSS SECTIONS

NO	DATE	DESCRIPTION	BY
D	01.14.20	ADDED ADA THRESHLD	TB
C	08.23.17	CHG'D CORE DEFIN.	JH
B	10.27.14	5TH ED CODE CHANGE	SM
A	12.01.11	2010 CODE CHANGE	JLA

DATE:	12/31/09
SCALE:	3" = 1'
DWG. BY:	R. LUBBECKE
CHK. BY:	S. FREY
DRAWING NO.:	JW162009
SHEET	7 OF 16

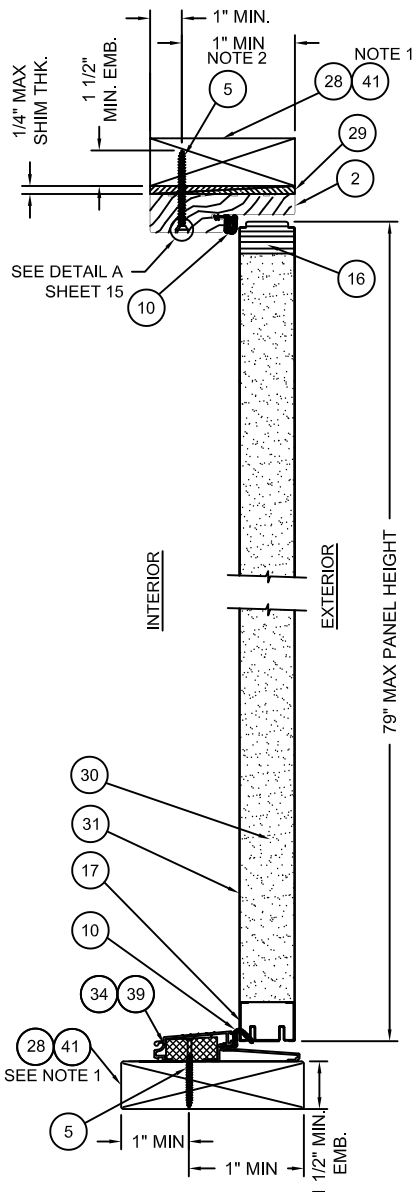

A VERTICAL CROSS SECTION, DOOR TYP.
9 WOOD FRAME INSTALLATION

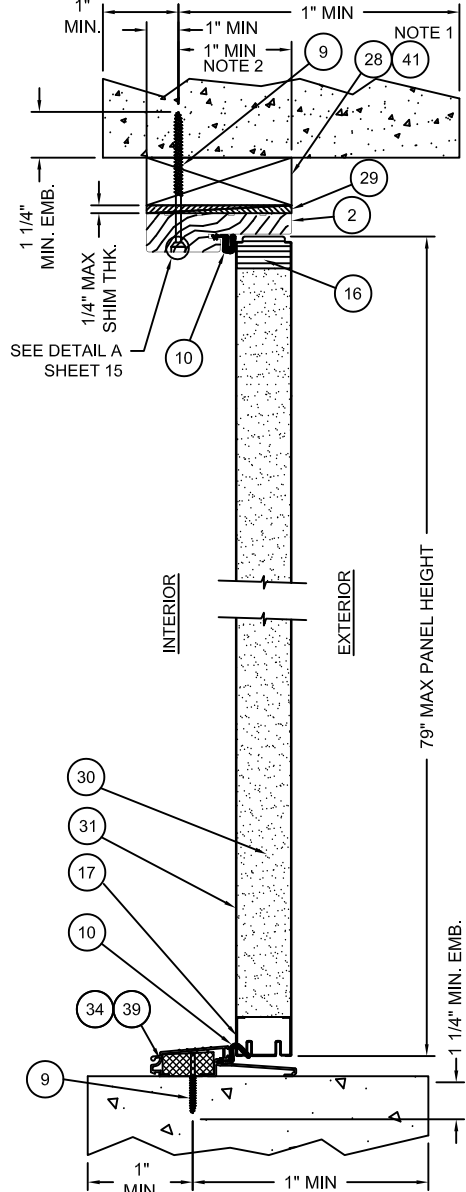

B VERTICAL CROSS SECTION, DOOR TYP.
9 MASONRY AND CONCRETE INSTALLATION

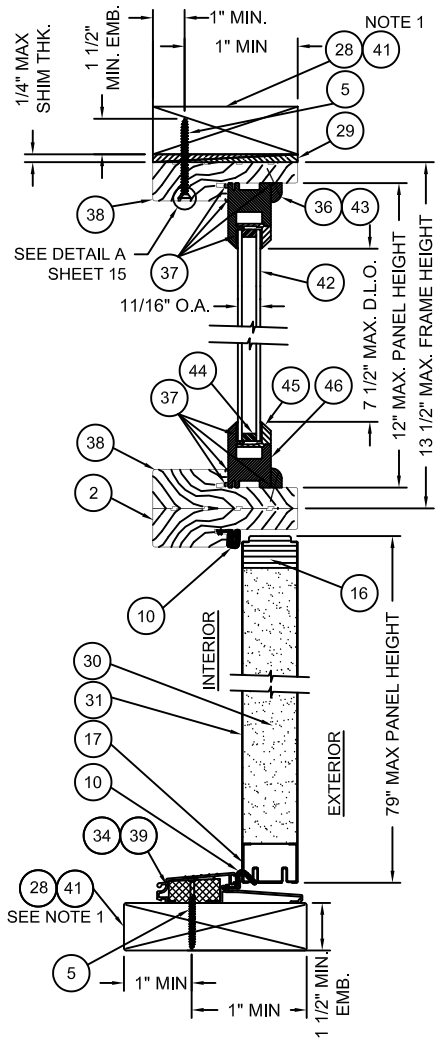

C VERTICAL CROSS SECTION, DOOR/TRANSOM TYP.
9 MASONRY AND CONCRETE INSTALLATION

NOTE 1- 1X MAY BE UTILIZED AS AN OPTION AS LONG AS MINIMUM ANCHOR EMBEDMENT DEPTH, INTO MASONRY, CONCRETE, OR WOOD IS MAINTAINED.
 NOTE 2- OPTIONALLY, ANCHOR CAN BE PLACED IN NARROW SECTION OF HEAD OF JAMB.

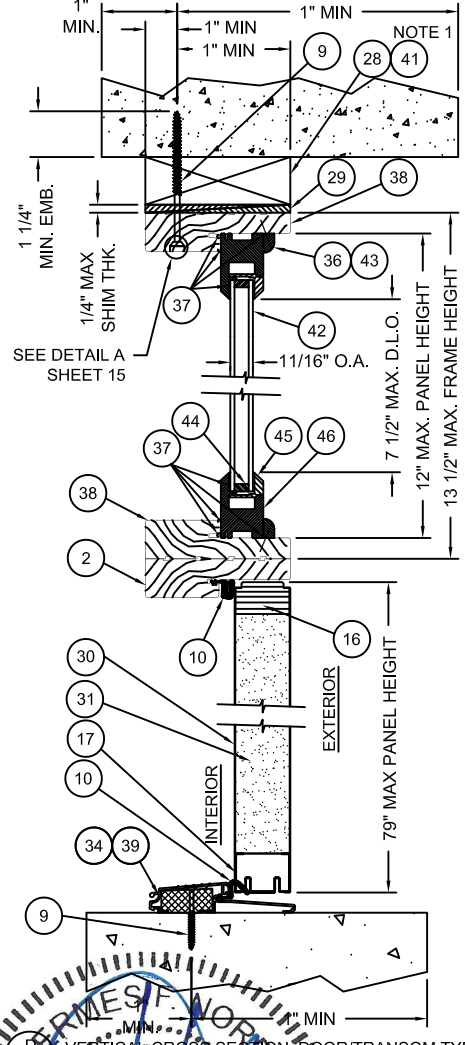

D VERTICAL CROSS SECTION, DOOR/TRANSOM TYP.
9 MASONRY AND CONCRETE INSTALLATION

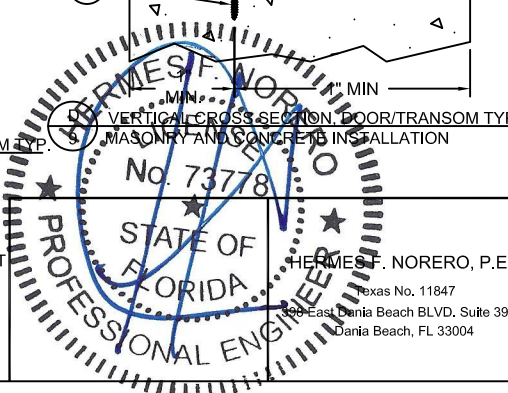

JELD-WEN, INC.
 3737 LAKEPORT BLVD.
 KLAMATH FALLS, OR, 97601
 PH. 541-882-3451

PRODUCT:
 CONTOURS STEEL DOOR, WOOD EDGE
 6-0x6-8 (XX) & 5-4x8-8 (O/OXO)
 INSWING/OUTSWING 24GA. STEEL
 PART OR ASSEMBLY:
 OUTSWING VERTICAL CROSS SECTIONS

NO.	DATE	DESCRIPTION	BY
D	01.14.20	ADDED ADA THRESHOLD	TB
C	08.23.17	CHGD CORE DEFIN	JH
B	10.27.14	5TH ED CODE CHANGE	SM
A	12.01.11	2010 CODE CHANGE	JLA

DATE: 12/31/09
 SCALE: 3" = 1"
 DWG. BY: LUBBECKE
 CHK. BY: S. FREY
 DRAWING NO.: JW162009
 SHEET 9 OF 16

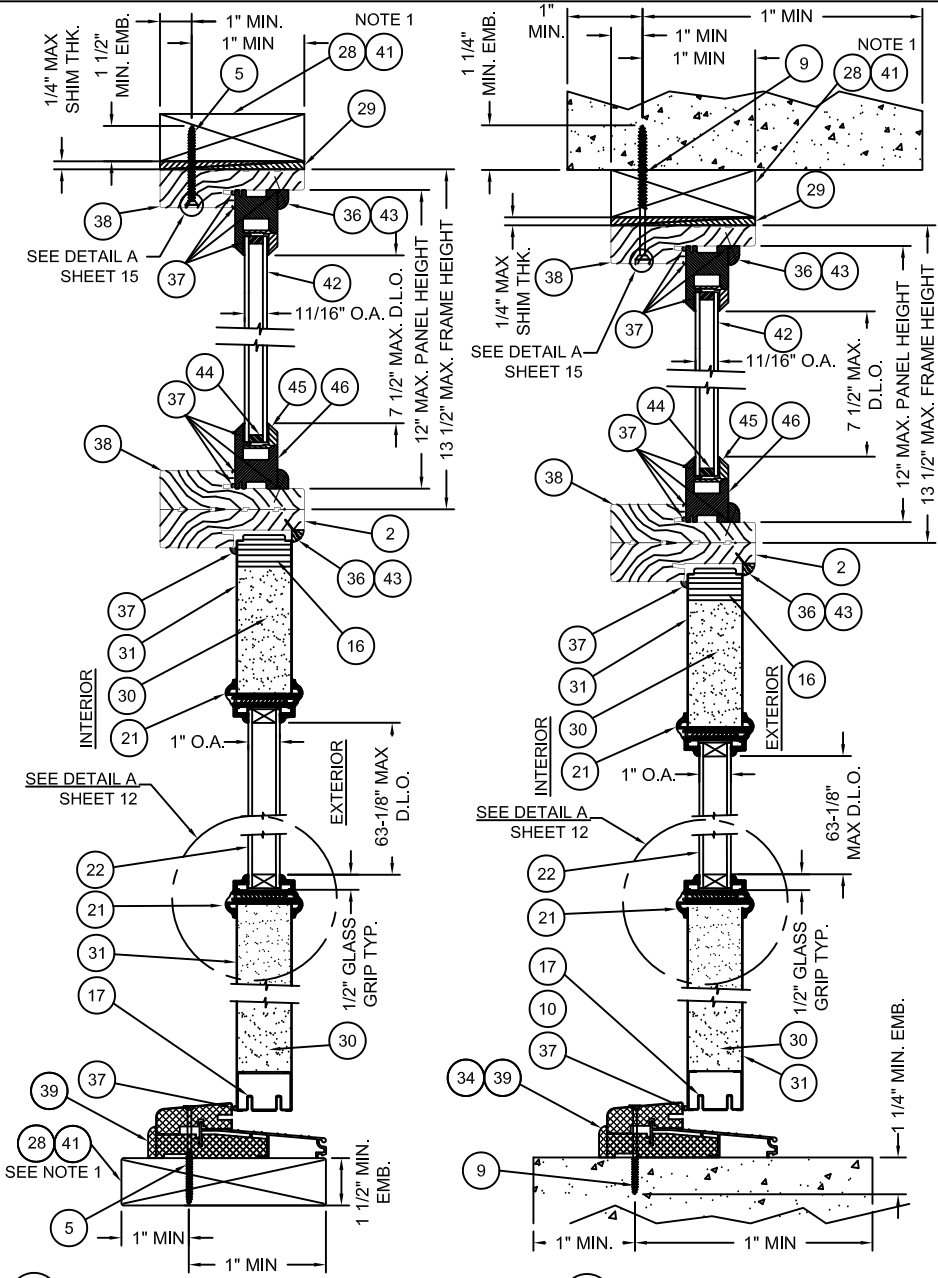

A VERTICAL CROSS SECTION SIDELITE /TRANSOM TYP. WOOD FRAME INSTALLATION

B VERTICAL CROSS SECTION SIDELITE /TRANSOM TYP. MASONRY AND CONCRETE INSTALLATION

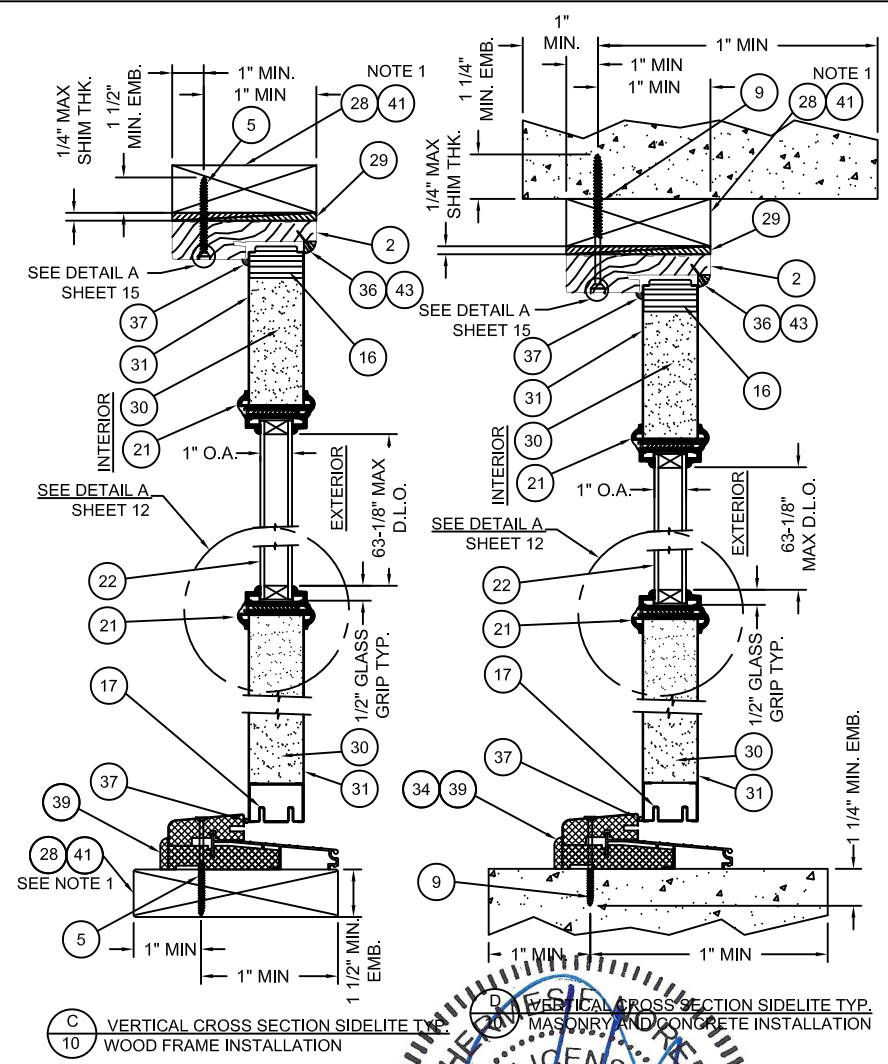

C VERTICAL CROSS SECTION SIDELITE TYP. MASONRY AND CONCRETE INSTALLATION

D VERTICAL CROSS SECTION SIDELITE TYP. MASONRY AND CONCRETE INSTALLATION

NOTE 1- 1X MAY BE UTILIZED AS AN OPTION AS LONG AS MINIMUM ANCHOR EMBEDMENT DEPTH, INTO MASONRY, CONCRETE, OR WOOD IS MAINTAINED.

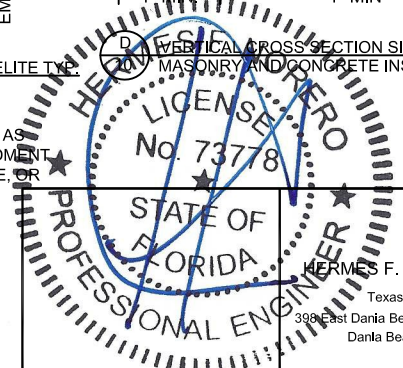

JELD-WEN, INC.
3737 LAKEPORT BLVD.
KLAMATH FALLS, OR, 97601
PH. 541-882-3451

PRODUCT:
CONTOURS STEEL DOOR, WOOD EDGE
6-0x6-8 (XX) & 5-4x6-8 (O/OXO)
INSWING/OUTSWING 24GA. STEEL
PART OR ASSEMBLY:
OUTSWING VERTICAL CROSS SECTIONS

NO.	DATE	DESCRIPTION	BY
D	01.14.20	ADDED ADA THRSILD	TB
C	08.23.17	CHG'D CORE DEFN.	JH
B	10.27.14	5TH ED CODE CHANGE	SM
A	12.01.11	2010 CODE CHANGE	JLA

DATE: 12/31/09
SCALE: 3" = 1"
DWG. BY: LUBBECKE
CHK. BY: S. FREY
DRAWING NO.: JW162009
SHEET 10 OF 16

HERMIS F. NORERO, P.E.
Texas No. 11847
398 East Dania Beach Blvd., Suite 398
Dania Beach, FL 33004

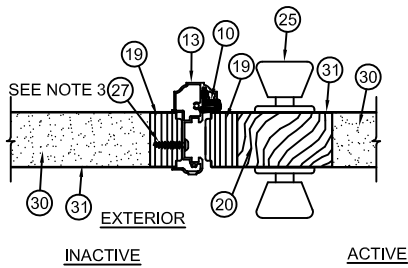

A HORIZONTAL CROSS SECTION
11 VIEW AT ASTRAGAL

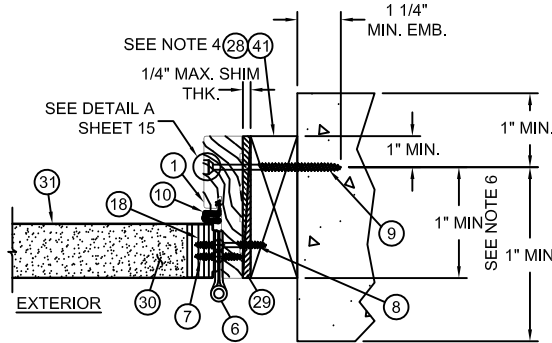

B HORIZONTAL CROSS SECTION
11 VIEW AT DOOR HINGE/SIDE JAMB
(MASONRY AND CONCRETE INSTALL)

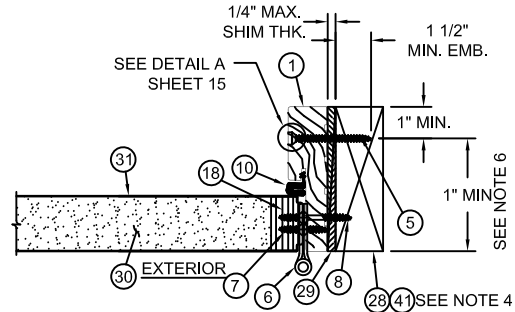

C HORIZONTAL CROSS SECTION
11 VIEW AT DOOR LATCH/SIDE JAMB
(WOOD INSTALL)

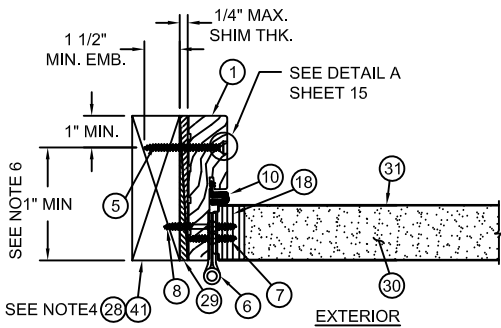

D HORIZONTAL CROSS SECTION
11 VIEW AT DOOR LATCH/SIDE JAMB
(WOOD INSTALL)

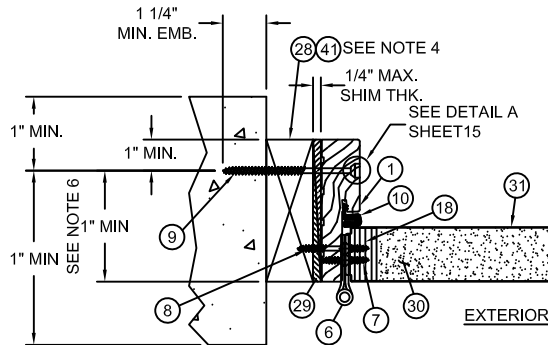

E HORIZONTAL CROSS SECTION
11 VIEW AT DOOR LATCH/SIDE JAMB
(MASONRY AND CONCRETE INSTALL)

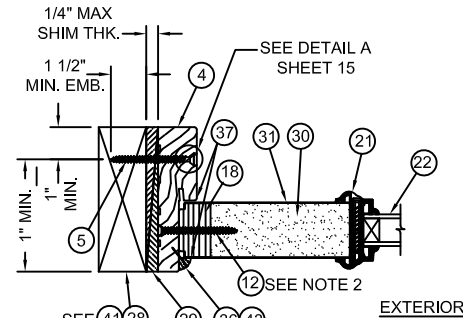

F HORIZONTAL CROSS SECTION
11 VIEW AT FIXED PANEL/SIDE JAMB
(WOOD INSTALL)

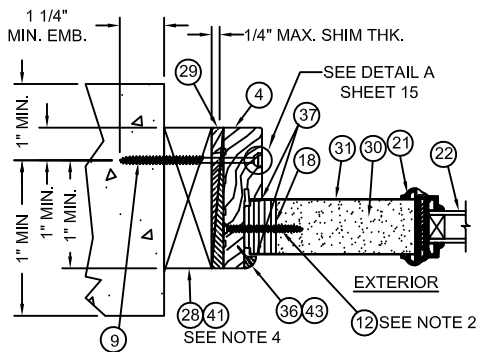

G HORIZONTAL CROSS SECTION
11 VIEW AT FIXED PANEL/SIDE JAMB
(MASONRY AND CONCRETE INSTALL)

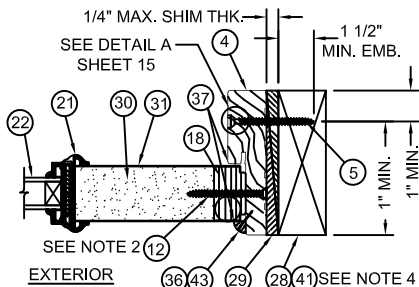

H HORIZONTAL CROSS SECTION
11 VIEW AT FIXED PANEL/SIDE JAMB
(WOOD INSTALL)

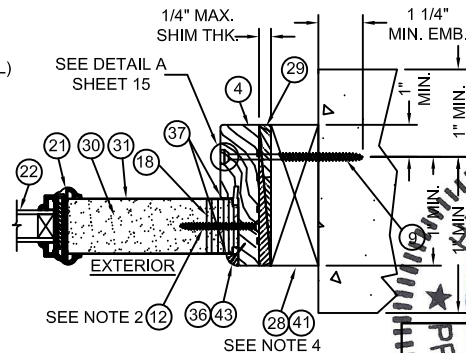

I HORIZONTAL CROSS SECTION
11 VIEW AT FIXED PANEL/SIDE JAMB
(MASONRY AND CONCRETE INSTALL)

NOTES

- FOR ANCHOR SPACING, SEE SHEETS 13, 14 & 15.
- SPACING FOR ITEM #12 FROM TOP DOWN: 6", 28-5/8", 50-7/8", 73-1/4".
- ASTRAGAL SCREW SPACING FOR ITEM #27 FROM TOP DOWN: 1/2", 3-1/2", 20", 24-3/4", 54-1/4", 59" & 78-1/2".
- WOOD MAY BE UTILIZED AS AN OPTION AS LONG AS MIN. ANCHOR EMBEDMENT DEPTH INTO MASONRY, CONCRETE, OR WOOD IS MAINTAINED.
- TAPCON (ITEM #5) ANCHOR SPACING SAME AS WOOD ANCHOR (ITEM #3) SPACING.
- DIAGONAL ANCHOR CAN BE PLACED IN NARROW SECTION OF HEAD OR JAMB.

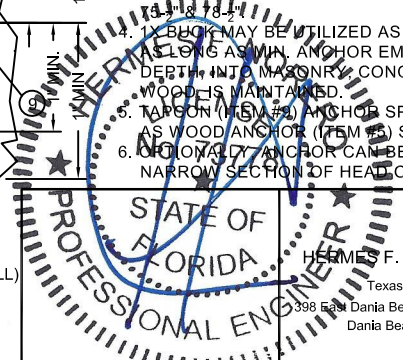

JELD-WEN, INC.
3737 LAKEPORT BLVD.
KLAMATH FALLS, OR, 97601
PH. 541-882-3451

PRODUCT: CONTOURS STEEL DOOR, WOOD EDGE
6-0x6-8 (XX) & 5-4x6-8 (O/OXO)
INSWING/OUTSWING 24GA. STEEL
PART OR ASSEMBLY:
OUTSWING HORIZONTAL CROSS SECTIONS

NO.	DATE	DESCRIPTION	BY	REVISIONS
D	01.14.20	ADDED ADA THRESHLD	TB	
C	08.23.17	CHGD CORE DEFN.	JH	
B	10.27.14	5TH ED CODE CHANGE	SM	
A	12.01.11	2010 CODE CHANGE	JLA	

DATE: 12/31/09
SCALE: 3" = 1'
DWG. BY: LUBBECKE
CHK. BY: S. FREY
DRAWING NO.: JW162009
SHEET 11 OF 16

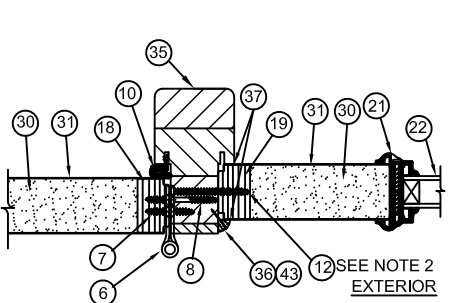

A HORIZONTAL CROSS SECTION
12 VIEW AT HINGED PANEL/SIDE LITE AND MULLION

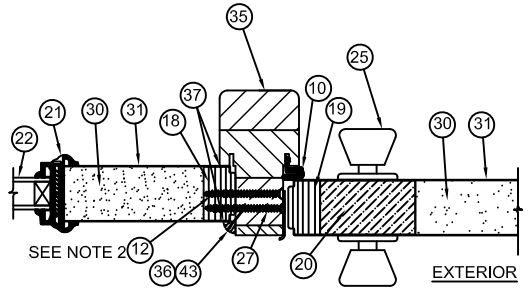

B HORIZONTAL CROSS SECTION
12 VIEW AT FIXED PANEL/DOOR LATCH AT MULLION

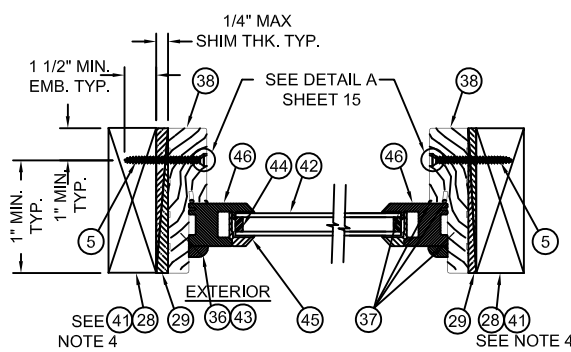

C HORIZONTAL CROSS SECTION
12 VIEW AT FIXED TRANSOM (WOOD INSTALL)

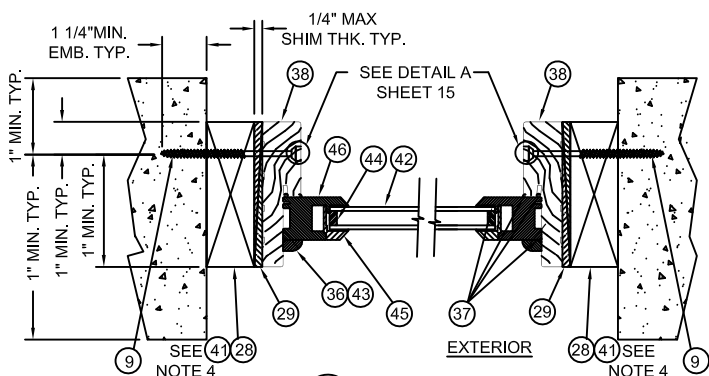

D HORIZONTAL CROSS SECTION
12 VIEW AT FIXED TRANSOM (MASONRY AND CONCRETE INSTALL)

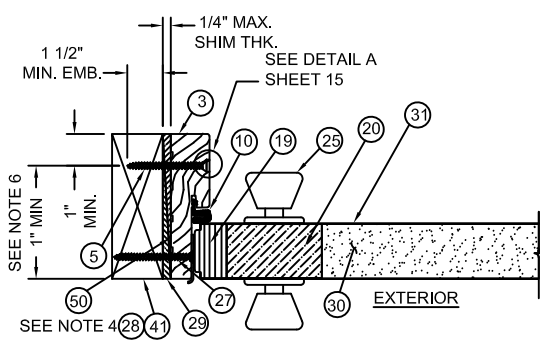

E HORIZONTAL CROSS SECTION
12 VIEW AT DOOR LATCH/SIDE JAMB (WOOD INSTALL)

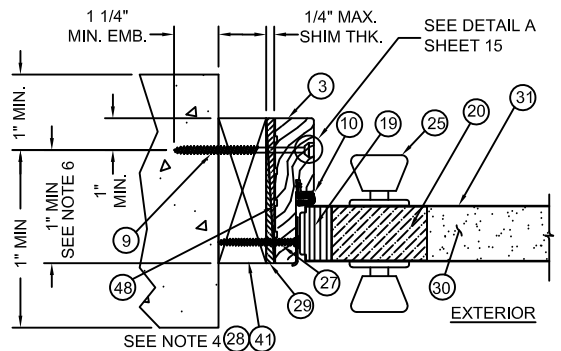

F HORIZONTAL CROSS SECTION
12 VIEW AT DOOR LATCH/SIDE JAMB (MASONRY AND CONCRETE INSTALL)

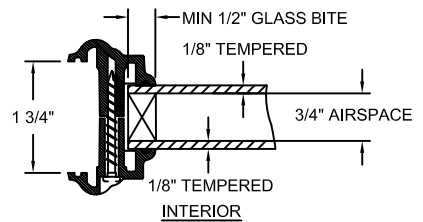

GLAZING DETAIL A
SCALE: 6"=1'-0"

- NOTES**
- FOR ANCHOR SPACING, SEE SHEETS 13, 14 & 15.
 - SPACING FOR ITEM #12 FROM TOP DOWN: 6", 28-3/8", 50-3/8", 73-3/8".
 - ASTRAGAL SCREW SPACING FOR ITEM #27 FROM TOP DOWN: 3/2", 3-1/2", 20", 24-3/8", 54-3/8", 59" 75-3/8" & 78-3/8".
 - 1X BUCK MAY BE UTILIZED AS AN OPTION AS LONG AS MIN. ANCHOR EMBEDMENT DEPTH, INTO MASONRY, CONCRETE, OR WOOD, IS MAINTAINED.
 - TAPCON (ITEM #9) ANCHOR SPACING SAME AS WOOD ANCHOR (ITEM #5) SPACING.
 - OPTIONALLY, ANCHOR CAN BE PLACED IN NARROW SECTION OF HEAD OR JAMB.

JELD-WEN, INC.
3737 LAKEPORT BLVD.
KLAMATH FALLS, OR, 97601
PH. 541-882-3451

PRODUCT:	CONTOURS STEEL DOOR, WOOD EDGE 6-0x6-8 (XX) & 5-4x6-8 (O/OXO)
INSWING/OUTSWING	24GA. STEEL
PART OR ASSEMBLY:	OUTSWING HORIZONTAL CROSS SECTIONS

NO.	DATE	DESCRIPTION	BY
D	01.14.20	ADDED ADA THRESHOLD	TB
C	08.23.17	CHGD CORE DEFIN.	JH
B	10.27.14	5TH ED CODE CHANGE	SM
A	12.01.11	2010 CODE CHANGE	JJA

DATE:	12/31/09
SCALE:	3" = 1'
DWG. BY:	G. LUBBECKE
CHK. BY:	S. FREY
DRAWING NO.:	JW162009
SHEET	12 OF 16

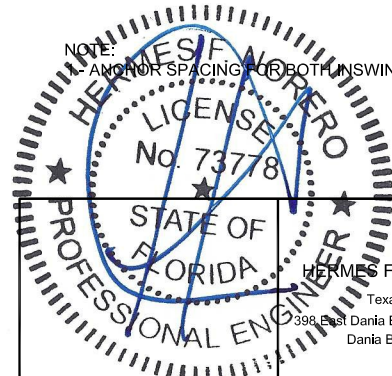
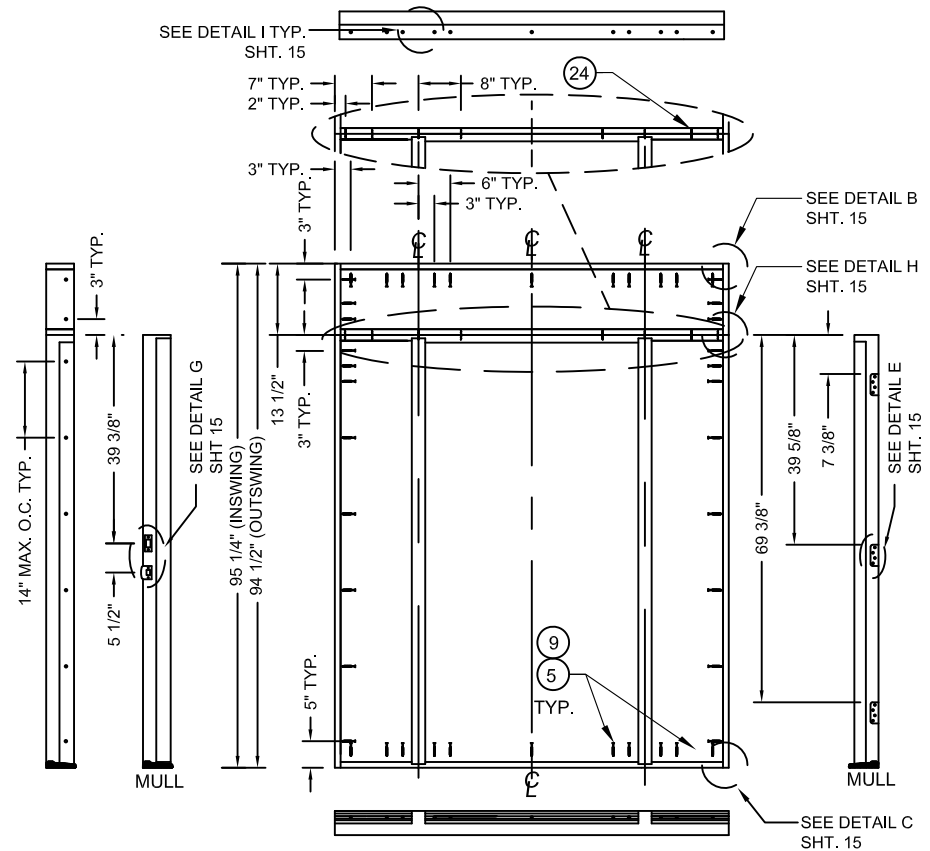
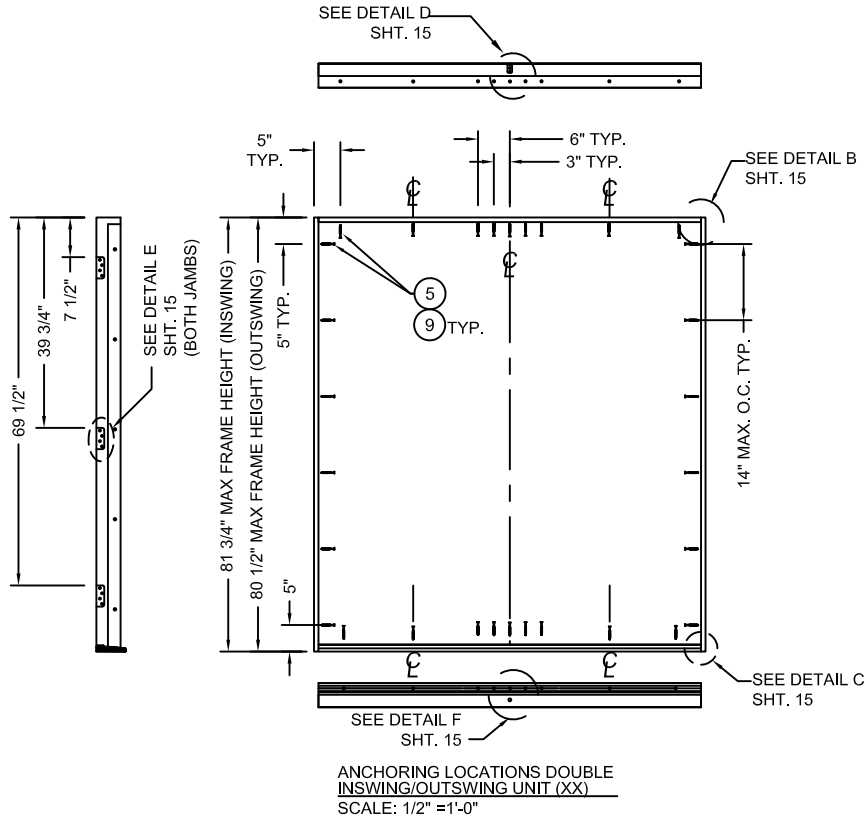

JELD-WEN, INC.
3737 LAKEPORT BLVD.
KLAMATH FALLS, OR, 97601
PH. 541-882-3451

PRODUCT:
CONTOURS STEEL DOOR, WOOD EDGE
6-0x6-8 (XX) & 5-4x6-8 (O/OXO)
INSWING/OUTSWING 24GA. STEEL
PART OR ASSEMBLY:
ANCHORING LOCATIONS
INSWING/OUTSWING

NO	DATE	DESCRIPTION	BY
D	01.14.20	ADDED ADA THRESHLD	TB
C	08.23.17	CHGD CORE DEFIN.	JH
B	10.27.14	5TH ED CODE CHANGE	SM
A	12.01.11	2010 CODE CHANGE	JLA

DATE: 12/31/09
SCALE: 1/2" = 1'
DWG. BY: S. LUBBECKE
CHK. BY: S. FREY
DRAWING NO.: JW162009
SHEET 13 OF 16

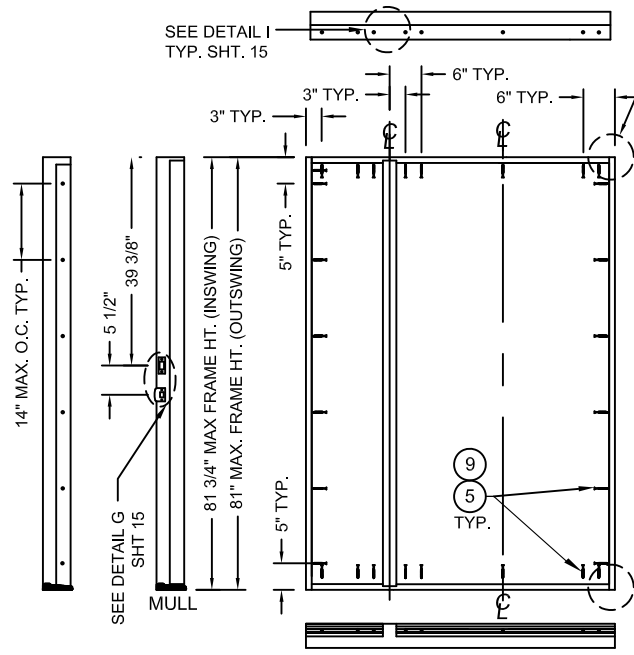

ANCHORING LOCATIONS DUAL UNIT
INSWING/OUTSWING UNIT (O/X)
SCALE: 1/2" = 1'-0"

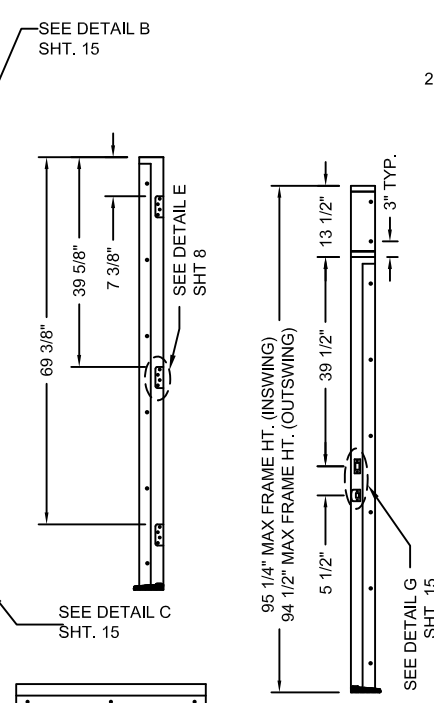

ANCHORING LOCATIONS SINGLE UNIT W/ TRANSOM
INSWING/OUTSWING UNIT (O/X)
SCALE: 1/2" = 1'-0"

ANCHORING LOCATIONS SINGLE UNIT
INSWING/OUTSWING UNIT (X)
SCALE: 1/2" = 1'-0"

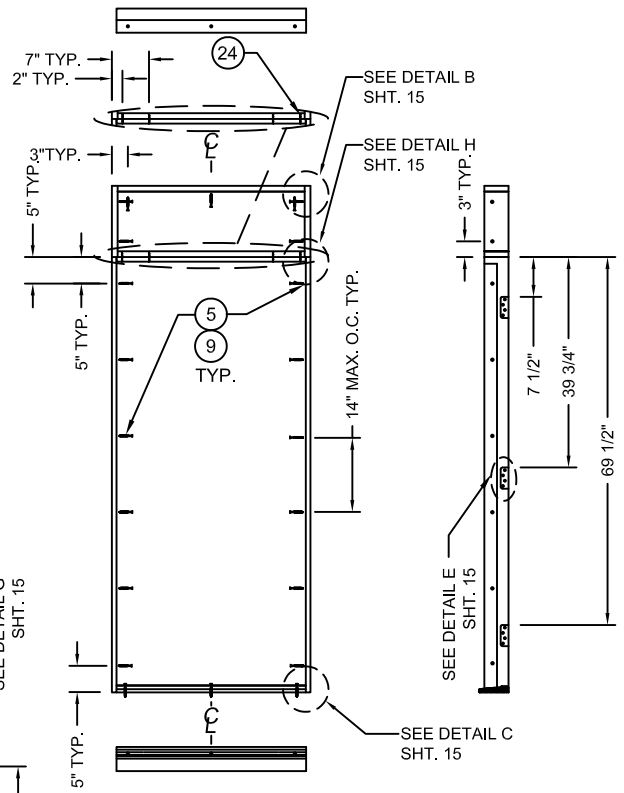

JELD-WEN, INC.
3737 LAKEPORT BLVD.
KLAMATH FALLS, OR, 97601
PH. 541-882-3451

PRODUCT:
CONTOURS STEEL DOOR, WOOD EDGE
6-0x6-8 (XX) & 5-4x6-8 (O/OXO)
INSWING/OUTSWING 24GA. STEEL
PART OR ASSEMBLY:
OUTSWING HORIZONTAL
CROSS SECTIONS

NO	DATE	DESCRIPTION	BY
D	01.14.20	ADDED ADA THRESHLD	TB
C	08.23.17	CHGD CORE DEFIN	JH
B	10.27.14	5TH ED CODE CHANGE	SM
A	12.01.11	2010 CODE CHANGE	JLA

DATE:	12/31/09
SCALE:	1/2" = 1'
DWG. BY:	G. LUBBECKE
CHK. BY:	S. FREY
DRAWING NO.:	JW162009
SHEET	14 OF 16

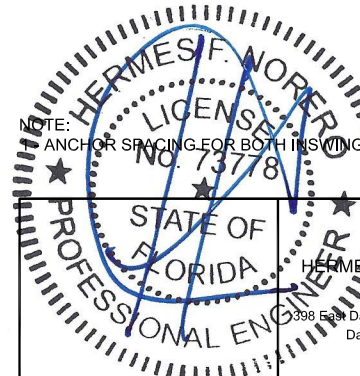

HERMES F. NORERO, P.E.
Texas No. 11847
398 East Dania Beach Blvd, Suite 398
Dania Beach, FL 33004

NOTE:
ANCHOR SPACING FOR BOTH INSWING & OUTSWING.

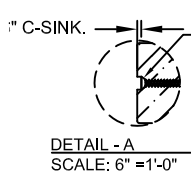
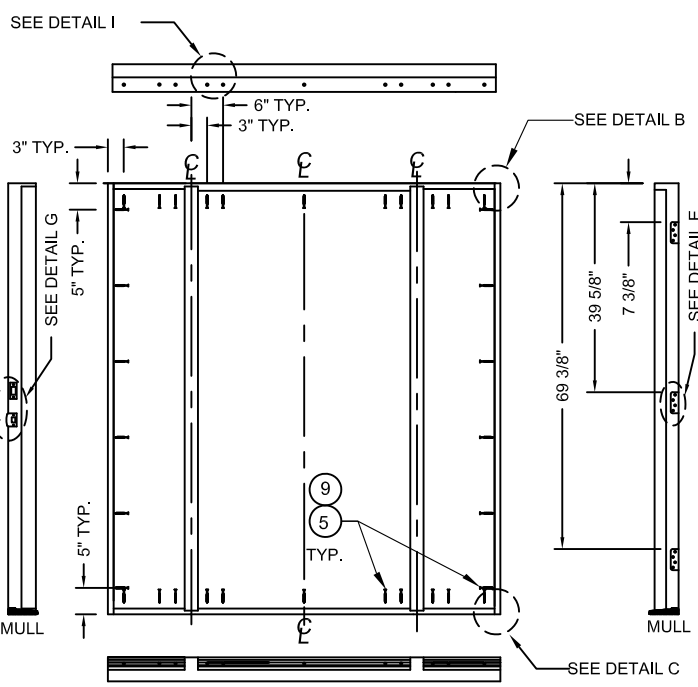

NOTE
 1 - USE #10 WOOD INSTALLATION SCREW W/ 1.50\"/>

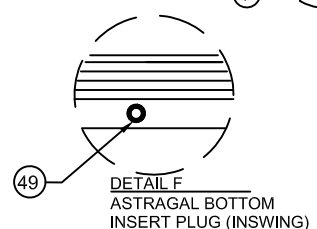
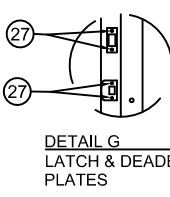
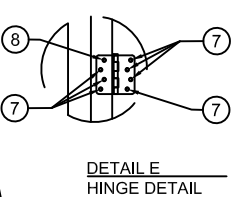
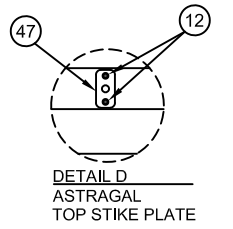
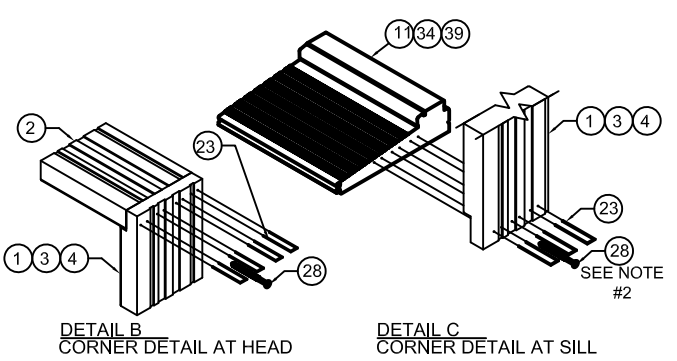

ANCHORING LOCATIONS TRI UNIT
 INSWING/OUTSWING UNIT (OXO)
 SCALE: 1/2\"/>

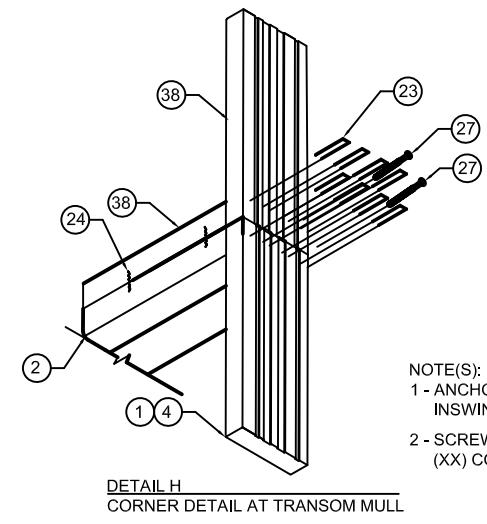
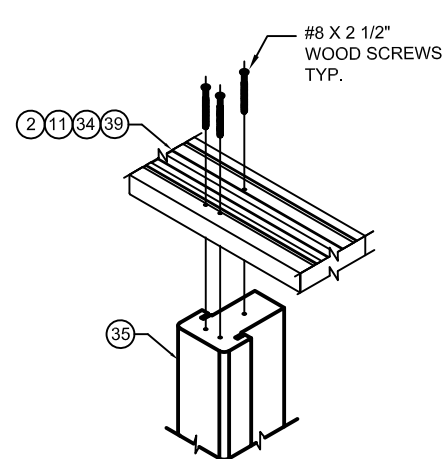

NOTE(S):
 1 - ANCHOR SPACING FOR BOTH INSWING & OUTSWING.
 2 - SCREW #28 IN DETAIL C, NOT USED IN (XX) CONFIGURATION.

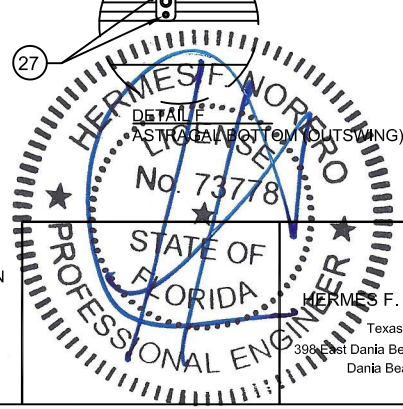

JELD-WEN, INC.
 3737 LAKEPORT BLVD.
 KLAMATH FALLS, OR, 97601
 PH. 541-882-3451

PRODUCT:
 CONTOURS STEEL DOOR, WOOD EDGE
 6-0x6-8 (XX) & 5-4x6-8 (O/OXO)
 INSWING/OUTSWING 24GA. STEEL
 PART OR ASSEMBLY:
 ANCHORING LOCATIONS
 & DETAILS

NO.	DATE	DESCRIPTION	BY
D	01.14.20	ADDED ADA THRESHLD	TB
C	08.23.17	CHG'D CORE DEFN.	JH
B	10.27.14	5TH ED CODE CHANGE	SM
A	12.01.11	2010 CODE CHANGE	JLA

DATE: 12/31/09
 SCALE: AS SHOWN
 DWG. BY: LUBBECKE
 CHK. BY: S. FREY
 DRAWING NO.: JW162009
 SHEET 15 OF 16

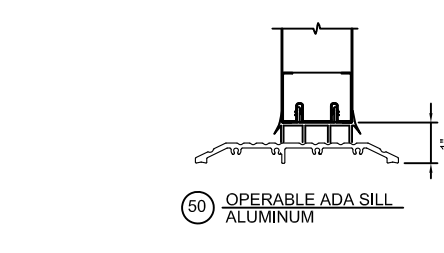
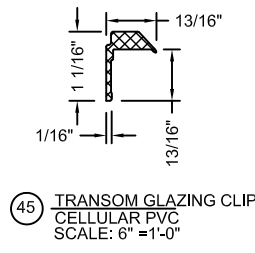
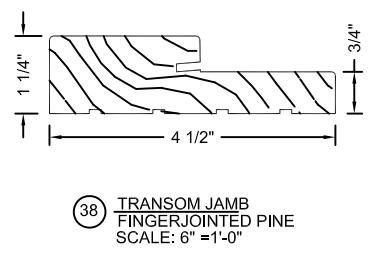
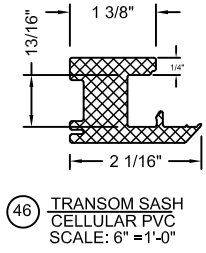
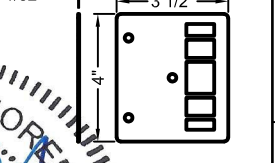
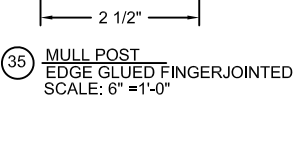
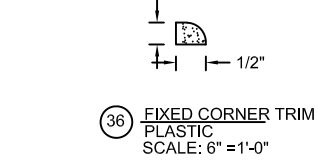
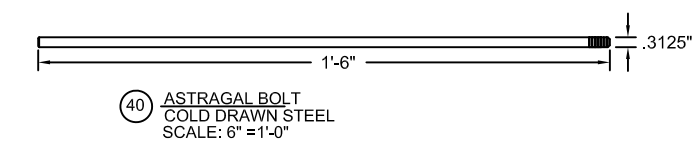
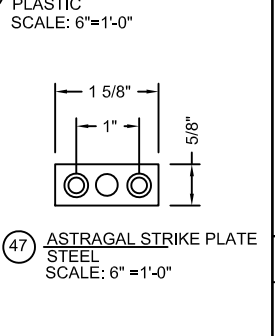
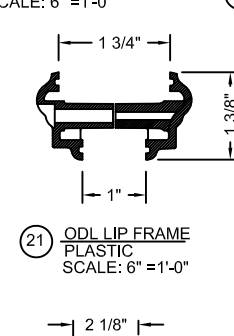
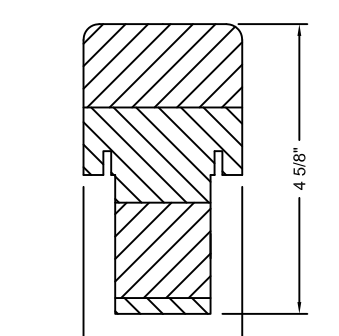
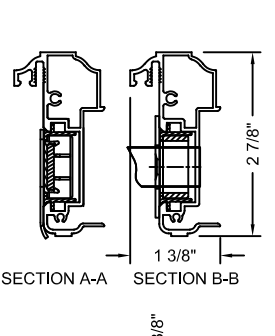
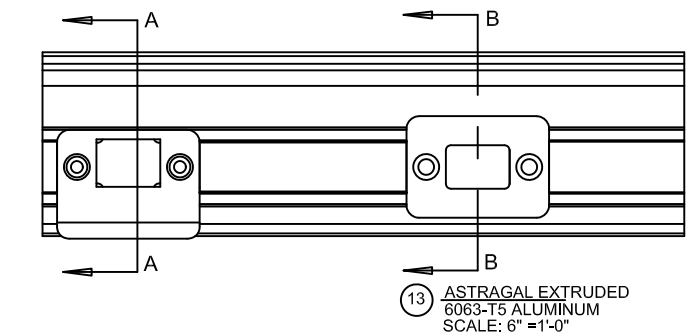
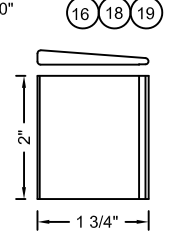
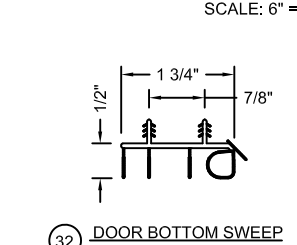
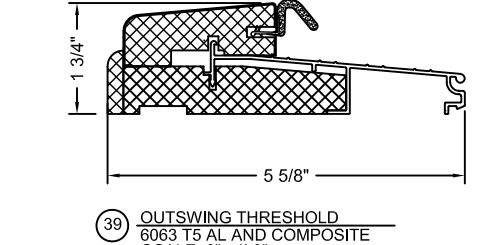
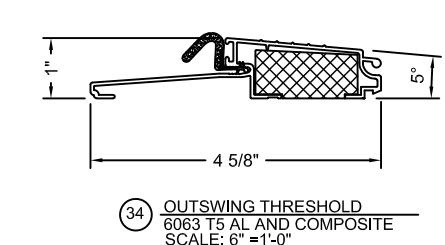
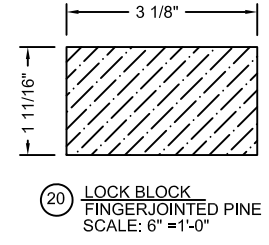
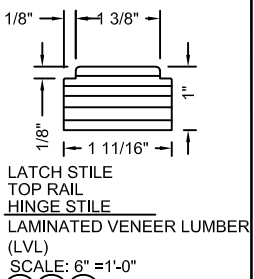
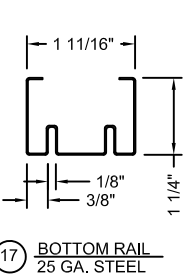
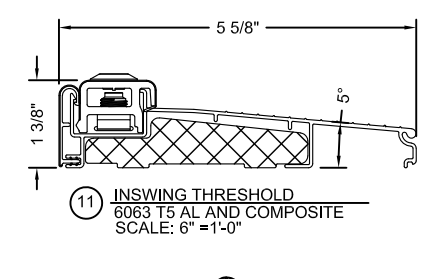
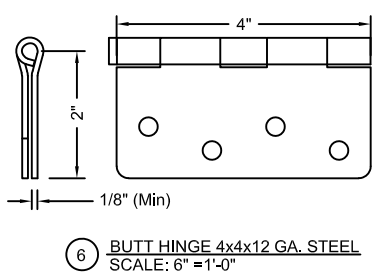
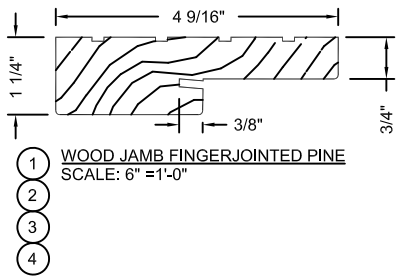

JELD-WEN, INC.
3737 LAKEPORT BLVD.
KLAMATH FALLS, OR, 97601
PH. 541-882-3451

PRODUCT: CONTOURS STEEL DOOR, WOOD EDGE
6-0x6-8 (XX) & 5-4x6-8 (O/OXO)
INSWING/OUTSWING 24GA. STEEL
PART OR ASSEMBLY:
UNIT COMPONENTS

NO	DATE	DESCRIPTION	BY
D	01.14.20	ADDED ADA THRESHLD	TB
C	08.23.17	CHGD CORE DEFIN.	JH
B	10.27.14	5TH ED CODE CHANGE	SM
A	12.01.11	2010 CODE CHANGE	JLA
		REVISIONS	

DATE: 12/31/09
SCALE: AS SHOWN
DWG. BY: S. LUBBECKE
CHK. BY: S. FREY
DRAWING NO.: JW162009
SHEET 16 OF 16